

Atlas Copco Instruction Manual



Instruction Manual
for Portable Light Tower Generator
English

HiLight V3+ WUX
HiLight V2+ WUX
HiLight P2+ WUX

Engine P2000I
Engine P3000
Engine P6500

Atlas Copco

**Instruction Manual
for Portable Light Tower Generator**

**HiLight V3+ WUX
HiLight V2+ WUX
HiLight P2+ WUX**

ATLAS COPCO - PORTABLE ENERGY DIVISION
www.atlascopco.com



Atlas Copco

The Atlas Copco logo consists of the brand name in a stylized, italicized serif font, centered between two thick, solid black horizontal bars.

Printed matter No.

9829 3868 00

11/2018

Warranty and Liability Limitation

Use only authorized parts.

Any damage or malfunction caused by the use of unauthorized parts is not covered by Warranty or Product Liability.

The manufacturer does not accept any liability for any damage arising from modifications, additions or conversions made without the manufacturer's approval in writing.

Neglecting maintenance or making changes to the setup of the machine can result in major hazards, including fire risk.

While every effort has been made to ensure that the information in this manual is correct, Atlas Copco does not assume responsibility for possible errors.

Copyright 2018, Atlas Copco (Wuxi) Compressor Co., Ltd.

Any unauthorized use or copying of the contents or any part thereof is prohibited.

This applies in particular to trademarks, model denominations, part numbers and drawings.

Preface

Please read the following instructions carefully before starting to use your machine. Follow the instructions in this booklet and we guarantee you years of trouble free operation.

Always keep the manual available near the machine. In all correspondence always mention the compressor type and serial number, shown on the data plate.

The company reserves the right to make changes without prior notice.

1	Safety precautions	7	7	Operation	23
1.1	Description of safety symbols used in the manual	7	7.1	Starting the engine of HiLight V3+ and HiLight V2+	23
1.2	Safety before use	7	7.2	Starting the HiLight P2+	24
1.3	Safety during use	7	7.3	Operating the LED lamps	25
1.4	Safety before servicing	8	8	Maintenance	26
1.5	Safety during servicing	8	8.1	Regular inspection	26
2	Leading particulars	9	8.2	Replacing the lamp	26
2.1	General description	9	8.3	Engine maintenance	27
3	Markings and information labels	12	9	Maintenance Schedule	28
4	Product drawings	13	10	Maintenance Schedule	29
4.1	General arrangement drawings	13	11	Technical Specifications	30
5	Circuit Diagrams	16	11.1	Reference conditions	30
5.1	Comprehensive wiring schematic diagram for lamp circuit	16	11.2	Limitations	30
5.2	Generator-capacitor excitation schematic diagram	17	11.3	Performance data	31
5.3	Trailer wiring diagram	18	11.4	Data plate	32
5.4	Comprehensive wiring schematic diagram for engine circuit	19			
6	Deployment and Operation	20			
6.1	Selecting a location	20			
6.2	Deployment Of HiLight V3+ and HiLight V2+	21			
6.3	Deployment of HiLight P2+	22			

SAFETY PRECAUTIONS

DESCRIPTION OF SAFETY SYMBOLS USED IN THE MANUAL



It tells the user about a risk or a dangerous procedure that can cause death.



It tells the user about a risk or a dangerous procedure that can cause injury to personnel or damage to equipment.



It gives precautions that must be obeyed for a process. It also gives the operator information about a process.

SAFETY BEFORE USE



Before using the HiLight V2+, HiLight V3+, or HiLight P2+, read the instruction manual carefully. Obey all instructions given in the manual.



Incorrect use of equipment can cause injury or death.



The light tower has moving parts. Moving parts can cut or crush body parts.

1. Make sure that the area available for the machine is clean and level with the ground. This will decrease risk of injury to personnel.
2. Make sure that there is a minimum distance of 1000mm around the machine.
3. Always drain the water collected in the frame of the light tower.
4. Make sure that the area above the light tower is clear of blockages.



If the light tower touches the overhead electrical power lines, it cause injury or death.

5. Make sure that the tires, lights, protective lamp covers, electrical wiring, and the engine are not worn out or damaged.



Do not use damaged equipment. It can cause injury or death.

SAFETY DURING USE

Light tower safety

- While raising or lowering the light tower mast, make sure the area behind it is clear of people. If the winch or the mast malfunction, stand away from the light tower and contact Atlas Copco.



Falling equipment can cause injury or death.

- Do not raise, lower, or move the light tower trailer while it is in operation.
- The light tower must be in the lowest position if it is not in operation or if there are high velocity winds

Engine safety

- To prevent explosion, do these steps:
 - Keep flammable items away from sparks and open flames.
 - Do not smoke near the engine.
 - Always stop the engine before filling or draining the fuel tank.
 - Do not use flammable solvents to clean parts.



Explosion can cause injury or death.

- To prevent suffocation, do these steps:
 - Operate the engine in an area with good airflow.
 - Stand away from the engine exhaust pipe.
 - Do the engine maintenance in an area with good airflow.
 - Fill or drain the fuel tank in an area with good airflow.



Engine exhaust and fuel fumes can cause breathing problems and death by suffocation.



CALIFORNIA PROPOSITION 65

The exhaust gas contains chemicals that can cause cancer, birth defects or cause problems in the reproductive system.

- To prevent fire or burns, do these steps:
 - Do not keep flammable items like fuel, leaves, paper etc around the exhaust pipe.
 - Do not touch the engine when it is in operation.
 - Do not open the fuel tank's filler cap when the engine is hot. The fuel tank contains hot pressurized gases. Leakage of this gas in air can start a fire.



SPARK ARRESTORS

A spark arrestor is a device that prevents fires. It collects the flammable particles in the exhaust gas. This makes the exhaust gas less flammable.



SPARK ARRESTORS

In some areas, engines that use hydrocarbon fuels must have spark arrestors. The State and local safety codes has a list of these areas. Make sure that the engine has spark arrestors, if the selected site area is there in that list.

SAFETY BEFORE SERVICING



Serviceing must be done by an approved technician. If there is a problem for serviceing, speak to Atlas Copco. All serviceing must be done when the engine is off and the power supply is disconnected.

- Switch off the power supply before serviceing the unit.
- Stop the engine and disconnect the battery's negative terminal
- Do the light tower serviceing in a dry area.
- Drain the light tower frame before serviceing.
- Clean the light tower before serviceing.
- Make sure that the service technician does the serviceing with dry hands and clothes.

SAFETY DURING SERVICING

- Keep hands, feet, and all loose clothing away from moving parts.
- Replace all damaged or missing labels.
- Use lifting and loading equipment, e.g. slings, hooks, chains, ramps, etc. of the correct rating. The gross vehicle weight rating of the light tower is given on its identification tag.
- Only the service technician must be near the unit. All other personnel must stand at a minimum distance of 1000mm around the unit.

LEADING PARTICULARS

GENERAL DESCRIPTION

The HiLight V3+, HiLight V2+ and HiLight P2+ are portable light-towers. They have LED (Light Emitting Diode) lamps that can illuminate an average area of 2000m².

HiLight V3+ and HiLight V2+

The HiLight V3+ and HiLight V2+ consist of the following parts:

HiLight V3+

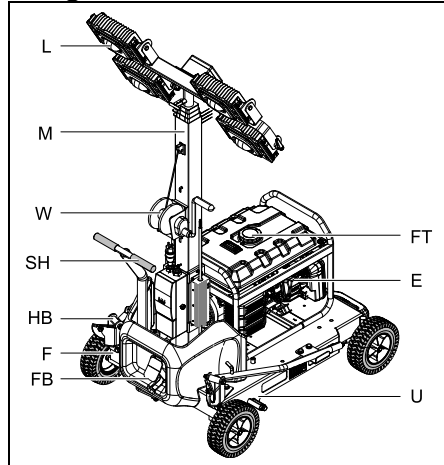

HiLight V2+

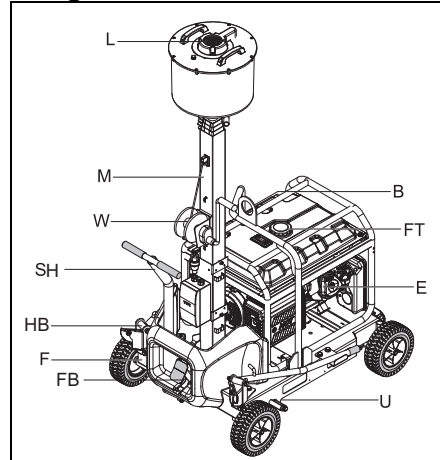

B	Beam
E	Engine
F	Frame
FT	Fuel Tank
FB	Foot Brake
HB	Hand Brake
L	Lamp
M	Mast
SH	Steering Handle
U	Undercarriage
W	Winch

Engine

The engine is coupled to a generator, which energizes the LED lamps. The engine operates on petrol.

LED lamp

The HiLight V3+ lamp configuration has 4 bulbs of 120 W. The bulbs have an average life of 50,000 operational hours.

The HiLight V2+ has a 320W balloon LED lamp. It is a non-inflatable balloon LED lamp. The lamp illuminates an area in all directions (360° area).

HiLight V3+

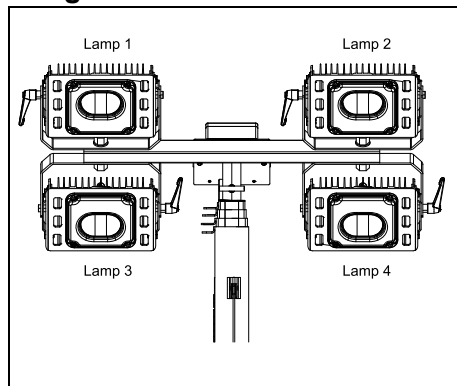

HiLight V2+

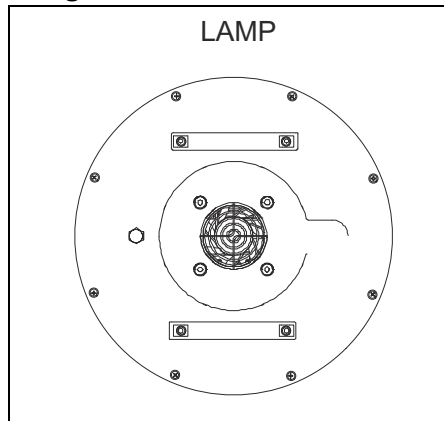

Safety devices

The circuit breakers are safety devices that protect the unit from over voltage.

Frame

The frame is a support for the mast, the generator, the engine and the towing equipment.

Lifting Beam

The lifting hook is accessible at the top of the unit.

Data plate

The data plate is on the Base frame of the light tower.

HiLight P2+

The HiLight P2+ is a light-weight and flexible light tower. It can be lifted and moved by the operator.

HiLight P2+

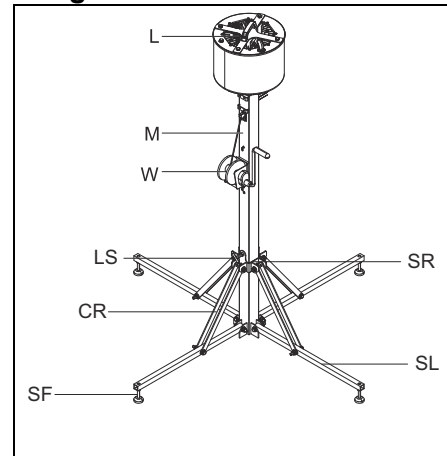

CR	Connecting rod
L	Lamp
LS	Locking screw
M	Mast
SR	Support ring
SL	Support leg
SF	Support foot
W	Winch

Power plug

The HiLight P2+ is a “Plug-and-light” light tower. It must be energized by a local power source.







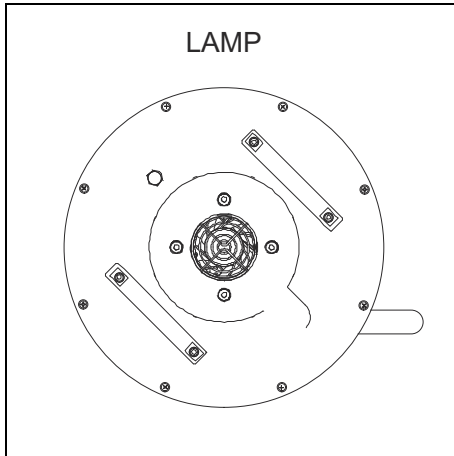



LED lamp





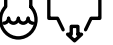

The HiLight P2+ has a 320W balloon LED lamp. It is a non-inflatable balloon LED lamp. The lamp illuminates an area in all directions (360° area).

HiLight P2+



MARKINGS AND INFORMATION LABELS

	Check oil level in engine
	Check coolant level
	Check petrol in the fueltank
	Read the instruction manual before filling oil
	Dangerous outlet gases.
	Danger, hot surface.
	Use petrol fuel only.
	Manual.
	Read the instruction manual before working on the battery.
	coolant drain
	Engine oil drain

	Drain condensate daily from vessel
	Rotation direction.
	Service point.
	Lifting permitted.
	Read the instruction manual before lifting.
	Start button
	Key switch

PRODUCT DRAWINGS

GENERAL ARRANGEMENT DRAWINGS

HiLight V3+

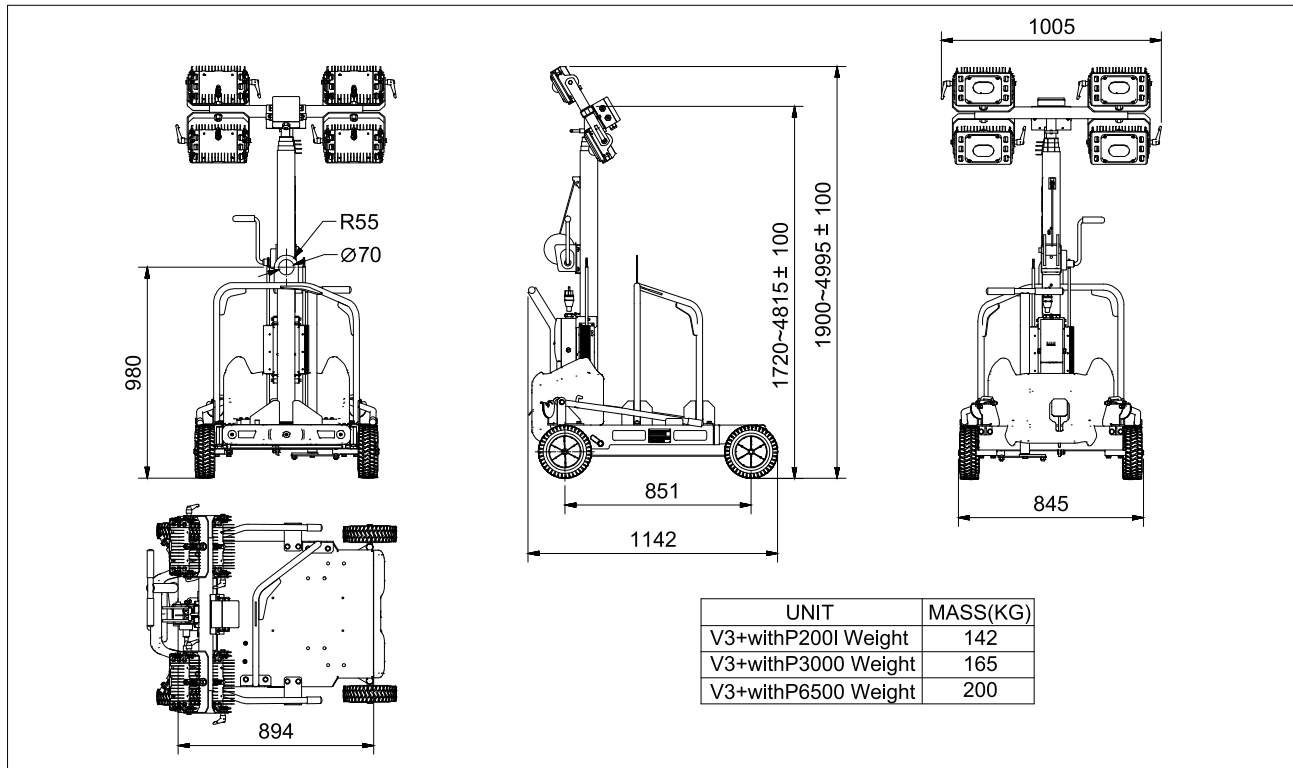

HiLight V2+

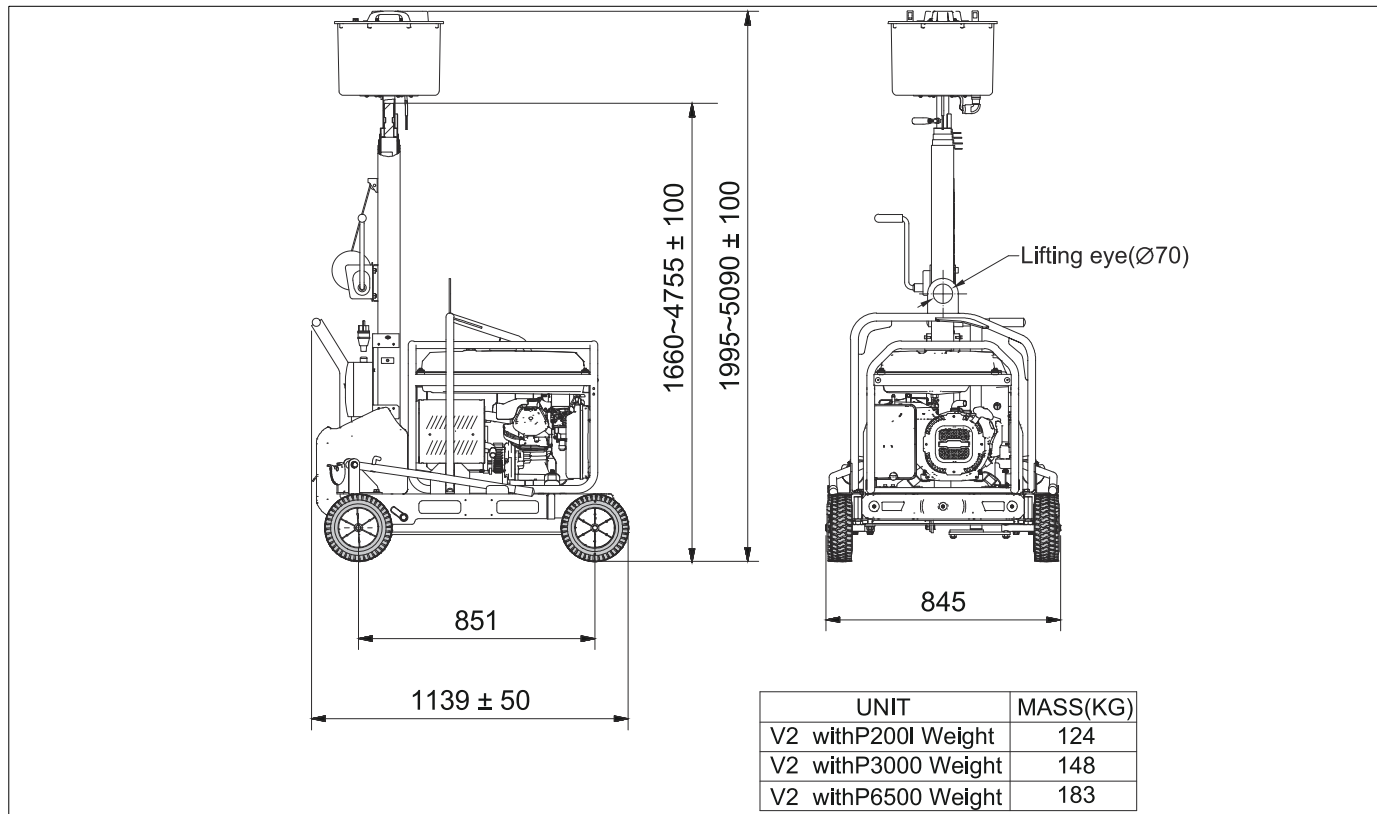

HiLight P2+

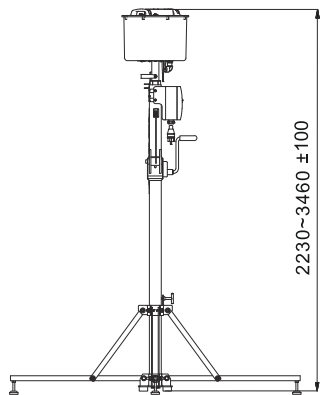

UNIT	MASS(KG)
P2 (contain Ballon Light)	52

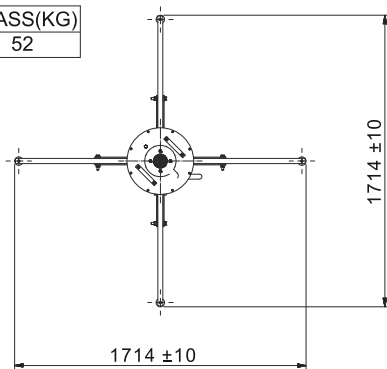

CIRCUIT DIAGRAMS

COMPREHENSIVE WIRING SCHEMATIC DIAGRAM FOR LAMP CIRCUIT- 9829 3800 74

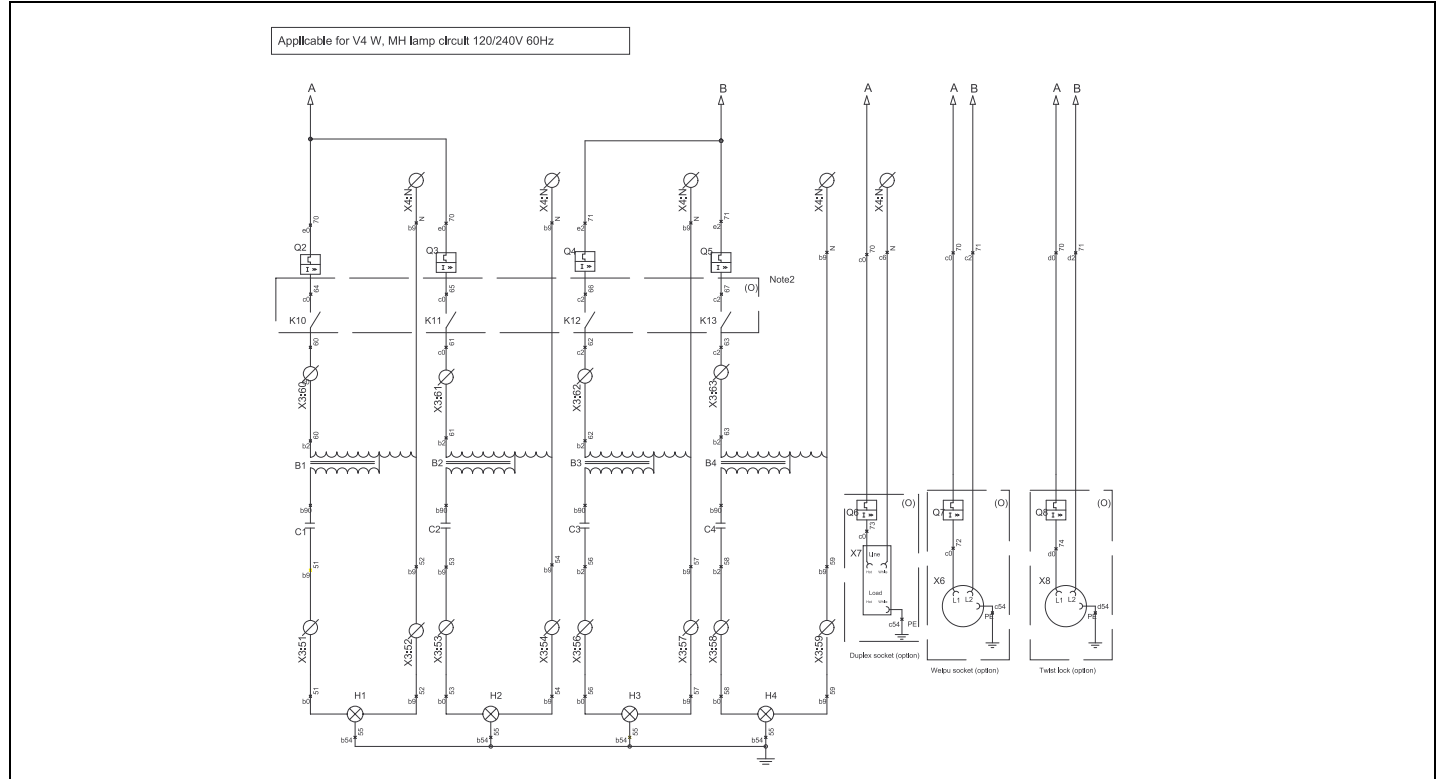

GENERATOR-CAPACITOR EXCITATION SCHEMATIC DIAGRAM

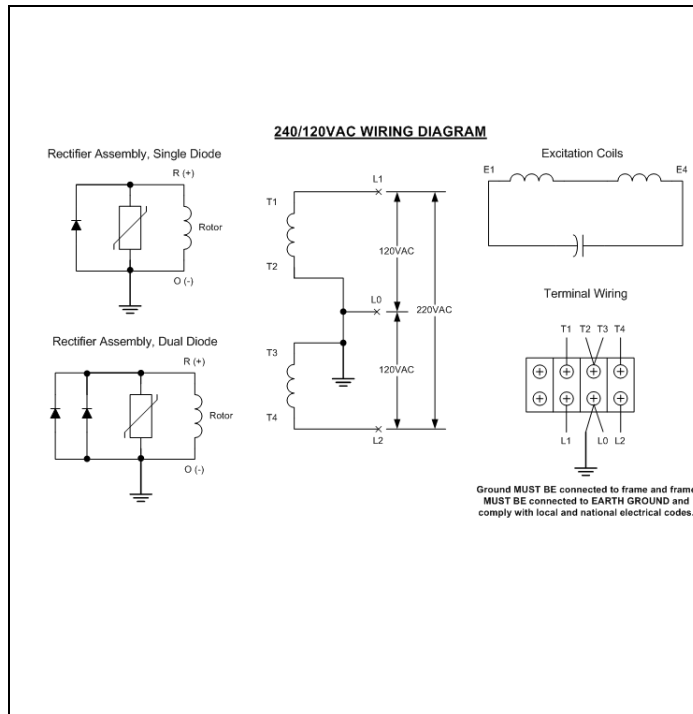

Reference	Description
1	Rotor
2	Stator
3	Excitation coils
4	Capacitor
5	Generator/terminal block
6	Control box lights

Wire Colours	
B	Black
Br	Brown
Cl	Clear
G	Green
Gr	Grey
L	Blue
LL	Light Blue
Or	Orange
P	Pink
Pr	Purple
R	Red
Sh	Shield
T	Tan
V	Violet
W	White
Y	Yellow

TRAILER WIRING DIAGRAM- 1094 2932 00

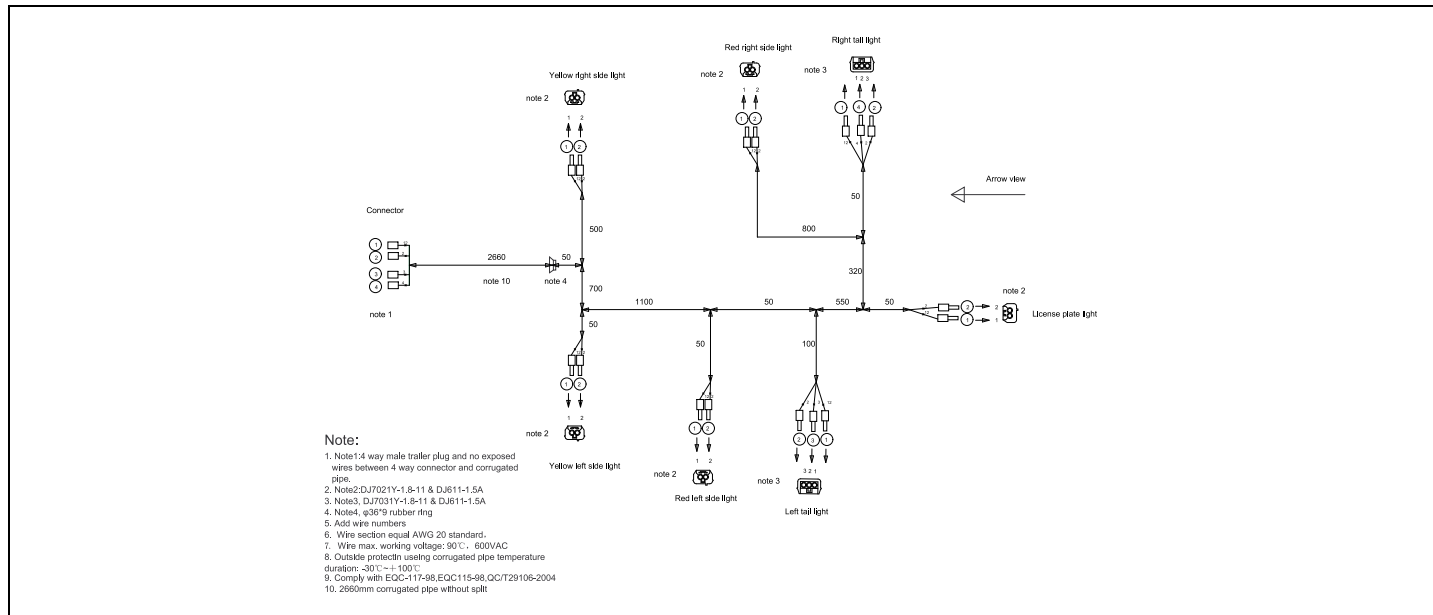

Reference	Description
a	Right stop, turn, and tail lights
b	Left stop, turn, and tail lights
c	Side light, amber
d	Side light, red
e	License plate light

Wire Colours		
G	Green	Right stop and turn lights
Y	Yellow	Left stop and turn lights
Br	Brown	License plate, tail, and side lights
W	White	Ground
R	Red	

COMPREHENSIVE WIRING SCHEMATIC DIAGRAM FOR ENGINE CIRCUIT - 9829 3800 78

CE Legend 1		CSA Legend 2	
Wire size	Other code	Wire size	Other code
• = 1 mm	• = black	• = AWG16	• = black
• = 1.5 mm	• = brown	• = AWG14	• = brown
• = 2.5 mm	• = red	• = AWG12	• = red
• = 4 mm	• = orange	• = AWG10	• = orange
• = 6 mm	• = yellow	• = AWG8	• = yellow
• = 10 mm	• = green	• = AWG6	• = green
• = 16 mm	• = blue	• = AWG4	• = blue
• = 25 mm	• = white	• = AWG2	• = white
• = 35 mm	• = grey	• = AWG0	• = grey
• = 50 mm	• = beige	• = AWG00	• = beige
• = 75 mm	• = green/yellow		
• = 95 mm			
• = 125 mm (EMC/CEP/BSI/ISO/IEC)			
• = 150 mm (BS/ISO/IEC)			
• = 185 mm (BS/ISO/IEC)			

Ma	Gr-Id	Man
A1	C6	Controller DSE L401
F1	F3	Fuse 30A
F2	F3	Fuse 10A
F3	F3	Fuse 10A
F4	F3	Fuse 5A
F5	F3	Fuse 5A
K1	C7	Relay
K2	C8	Relay
K3	C8	Relay
K4	C8	Relay
K10	E6	Relay
K11	E6	Relay
K12	E7	Relay
K13	E7	Relay
K100	E6	Relay
KT1	C7	Timer
P1	C10	Photo relay
P1.1	C10	Photo sensor
S5a	E6	Emergency stop switch
S5b	D2	Emergency stop switch
S10	A4	REMOTE/OFF/ON switch
X1	G2	Connector
N2	E5	Solenoid liner
X4	E3	Terminal

Symbol	S20	12	5.6	7.5
	REMOTE			
	OFF			
	ON			

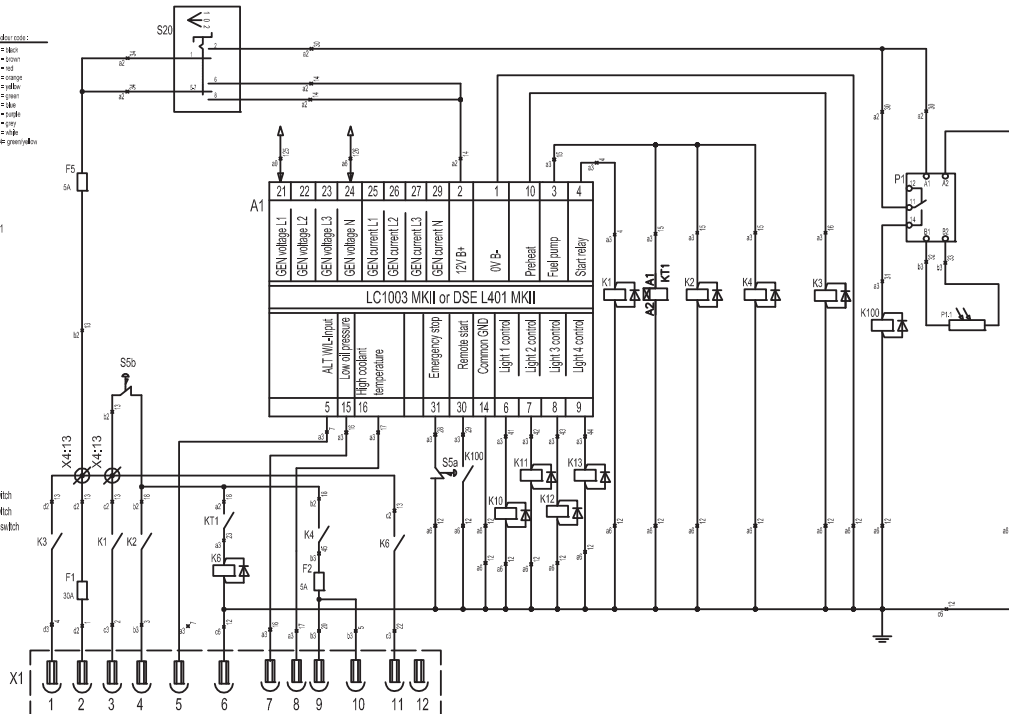

- Notes.
1. For CE or CSA cubicles, wires should be comply with CE or CSA
 2. Other circuit refer to 9829380074 except 9829380074-02

DEPLOYMENT AND OPERATION



Before using the HiLight V2+ or HiLight V3+ or HiLight P2+, read the instruction manual carefully. Obey all instructions given in the manual.

SELECTING A LOCATION

- Make sure that the speed of the wind at the location does not exceed 50km/hr.
- Put the light tower at the same level or at a higher level than the location to be illuminated. This gives the best light coverage.
- Make sure that the location is clean and level with the ground. This will decrease risk of injury to personnel, and risk of the light tower moving or falling.
- Make sure that the location is easy to access.
- The light tower mast can be raised to 18ft (5.5m). Make sure that the area above the light tower is clear.

LIFTING

Lifting HiLight V3+ and HiLight V2+

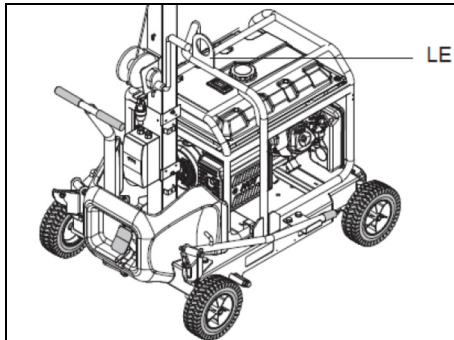

- The lifting eye (LE) for the unit is above the engine.
- Use lifting and loading equipment, e.g. slings, hooks, chains, ramps, etc. of the correct rating. The gross vehicle weight rating of the light tower is given on its identification tag.

Lifting HiLight P2+

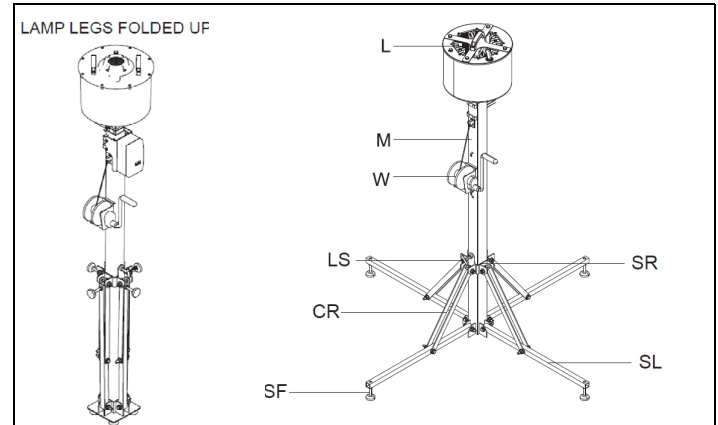

- Remove the Locking screw (LS) and bring the locking ring (SR) to the lowest position. Do not re-fit the locking screw (LS).
- The Support legs (SL) are hinged to the connecting rod (CR) and the base of the mast (M). The connecting rod (CR) is hinged to the locking ring (SR). Fold the support legs (SL) up such that they touch the light tower mast (M).



CAUTION FOR LOCKING SCREW:

If care is not taken, the locking screw (LS) can scratch the mast (M) or prevent the inner mast from getting raised.

- To prevent scratches, do not let the locking screw (LS) touch the mast (M) while changing the position of the locking ring (SR).
- Rotate the locking screw (LS) so that it is inserted in the hole of the outer mast (M) only. Always take this precaution before running the winch to prevent damage to the inner mast and to make sure that the inner mast can be raised.

- Refit the locking screw (LS) to the mast at the closest position.



Not refitting the locking screw (LS) while transporting the folded HiLight P2+ can lead to injury.

- Put the folded unit into its carry-case. Lift the carry-case by hand.

DEPLOYMENT OF HiLight V3+ AND

HiLight V2+



Before using the HiLight V2+ or HiLight V3+, read the instruction manual carefully. Obey all instructions given in the manual.

Towing

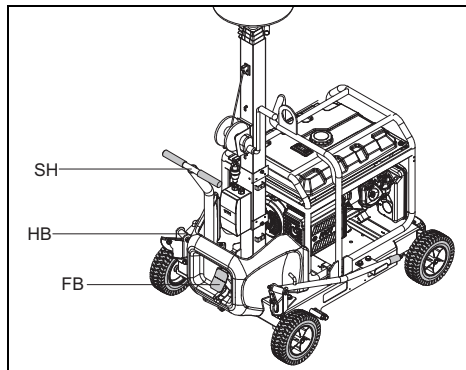

1. Before towing

- Always tow the light tower when the mast is at its lowest position.
- Attach a red flag on the top of the mast before towing the light tower.
- Check tires for wear. Do not use worn out tires.
- Make sure that the tires are inflated to the correct pressure.
- Make sure that the wheel lugs are tight.
- Make sure that the breaks are in good operating condition.
- Make sure that the steering system is in good operating condition.

2. During towing

- Do not load the unit with parts or tools.
- Do not tow light towers one after the other as a group.
- Maximum permitted towing speed on the highway is 45mph (72km/h). Maximum permitted towing speed on rough land is 10mph (16km/h).
- Follow all the applicable 'Department Of Transportation' (DOT) regulations.

3. After Towing

- Press the foot break (FB) to prevent the unit from moving.
- Set the hand break (HB) on the wheel to prevent them from moving.
- Release the foot break (FB).
- Move the towing vehicle away from the unit.

DEPLOYMENT OF HiLight P2+



Before using the HiLight P2+, read the instruction manual carefully. Obey all instructions given in the manual.

Setting up HiLight P2+

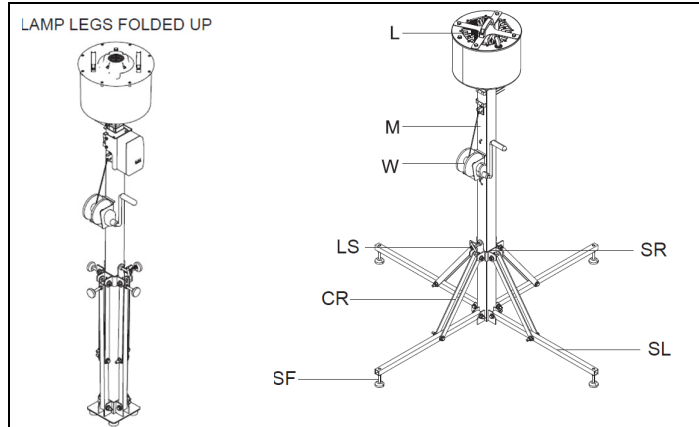

1. Remove the unit from the carry-case.
2. Remove the Locking screw (LS).
3. Put the unit on the ground with its support legs (SL) unfolded on the ground as shown.
4. Fit the locking ring (SR) to the mast (M) with a locking screw (LS). The light tower mast (M) has 2 holes in the vertical direction. The locking ring (SR) can be fitted to the mast (M) in these 2 positions.



CAUTION FOR LOCKING SCREW:

If care is not taken, the locking screw (LS) can scratch the mast (M) or prevent the inner mast from getting raised.

- To prevent scratches, do not let the locking screw (LS) touch the mast (M) while changing the position of the locking ring (SR).
- Rotate the locking screw (LS) so that it is inserted in the hole of the outer mast (M) only. Always take this precaution before running the winch to prevent damage to the inner mast and to make sure that the inner mast can be raised.

OPERATION

STARTING THE ENGINE OF HiLight V3+ and HiLight V2+



Before starting the HiLight V2+ or HiLight V3+, read the instruction manual carefully.

1. Before starting the engine

- Obey all safety instructions given in section **Engine safety**
- Check engine oil, fuel and coolant levels. Do not operate the engine if the fuel tank is empty or if fuel level is below minimum mark.
- Use only petrol fuel.
- Prime the engine fuel lines if the fuel tank was empty or while using the engine for the first time. Refer the engine manual for priming procedure.
- Make sure that the light tower circuit breakers are set to "OFF" position.

2. Starting the engine

1. Insert the engine key in the key slot on the engine.
2. Turn the key clockwise for one "click". This will illuminate the glow plug.
3. Crank the engine only after the glow plug light goes off. The glow plug stays illuminated till the engine starter coil temperature becomes equal to the set temperature.
4. Turn and hold the key in the "START" position for 10 seconds.

5. Release the key when the engine starts. Release the key if the engine does not start in 10 seconds.



Do not hold the key for more than 10 seconds. Release the key if the engine does not start in 10 seconds. Do not try to start the engine immediately. It will cause the engine to overheat. This will damage the starter motor. Wait for 30 seconds before starting the engine again.

6. The engine will shut down automatically if oil pressure does not increase to set pressure in 30 seconds after starting.



Before starting the HiLight V2+ or HiLight V3+, read the instruction manual carefully. Obey all safety instructions given in section **Engine safety**.

3. Stopping the engine

1. Stop the power supply to the bulbs and externally connected devices.



Always break the electrical circuit before stopping the engine. This prevents damage to the LED lamps and generator.

2. Turn the engine key to the off position.

4. Automatic engine shutdown

The engine has an auto-shutdown system. This system makes the engine shut down automatically if the oil pressure is too low or if the engine temperature is too high. This prevents damage to engine components.

The engine starting procedure after auto-shutdown is

as below:

1. Turn the key to "OFF" position and wait for 60 seconds.
2. Turn the key clockwise for one "click". This will illuminate the glow plug.
3. Crank the engine only after the glow plug light goes off. The glow plug stays illuminated till the engine starter coil temperature becomes equal to the set temperature.
4. Turn and hold the key in the "START" position for 10 seconds.
5. Release the key when the engine starts. Release the key if the engine does not start in 10 seconds.



Do not hold the key for more than 10 seconds. Release the key if the engine does not start in 10 seconds. Do not try to start the engine immediately. It will cause the engine to overheat. This will damage the starter motor. Wait for 30 seconds before starting the engine again.

6. The engine will shut down automatically if oil pressure does not increase to set pressure in 30 seconds after starting.



Before starting the HiLight V2+ or HiLight V3+, read the instruction manual carefully. Obey all safety instructions given in section **Engine safety**.

STARTING THE HiLight P2+

The HiLight P2+ is a “plug-and-use” light tower. It must be connected to a power source to energize the lamp.

Raising and lowering the light towers



Falling equipment can cause injury or death.

1. Raising



- The operator should prevent twisting and pinching of cables and wires while raising the tower mast.
- De-energize the light tower before raising the tower. Touching live electrical circuits can cause electric shock and can result in injury or death.

a) Raising the mast

1. Rotate the handle of the winch (1) till the lamp reaches the necessary height.

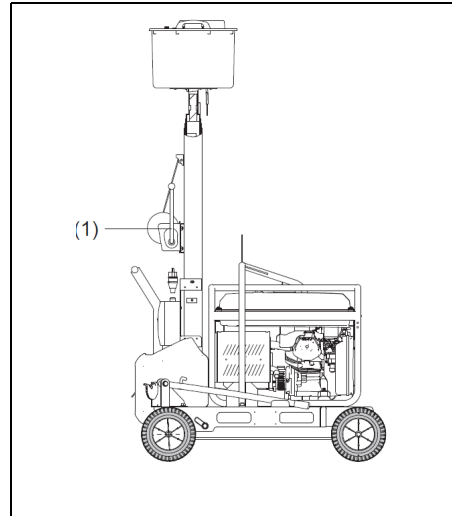

b) Adjusting the lamp direction for HiLight V3+

1. Unscrew the locking pin (1) and rotate the light tower mast (2) to change direction of illumination.
2. Screw the locking pin (1) to the mast (2) after rotating it.
3. Loosen the knob (3) of an individual lamp (4) to change its orientation. The lamp (4) can be moved along its horizontal axis, as needed.
4. Tighten the knob (3) after adjusting the orientation of the lamp (4)

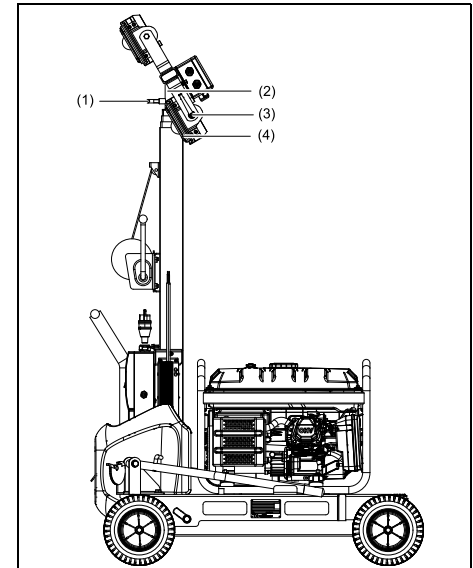

2. Lowering



Before moving the light tower, lower the mast and lock it in place. This prevents injury caused by falling objects.



- The operator should prevent twisting and pinching of cables and wires while lowering the tower mast.
- De-energize the light tower before lowering the tower. Touching live electrical circuits can cause electric shock and can result in injury or death.

- a) Lowering the mast
 1. De-energize the LED lamps by disconnecting power supply or by shutting down the engine.
 2. Rotate the handle of the winch (1) till the mast reaches the lowest level.

OPERATING THE LED LAMPS



De-energize the light tower before touching the LED lamps. Touching live electrical circuits can cause electric shock and can result in injury or death.

1. Energizing the LED lamps

- a) Energizing LED lamps for HiLight V3+ and HiLight V2+
 1. Start the engine. Refer to section Starting the engine of HiLight V3+ and HiLight V2+
 2. Switch the circuit breaker to "ON" position. LED lamp energizes instantly.
- b) Energizing LED lamp for HiLight P2+
 1. Connect the light tower plug to the main power supply.
 2. Switch the circuit breaker to "ON" position. LED lamp energizes instantly.

2. De-energizing the LED lamps

- a) De-energizing the LED lamps for HiLight V3+ and HiLight V2+.



Always break the electrical circuit before stopping the engine. This prevents damage to the LED lamps and generator.

- a) De-energizing the LED lamps for HiLight P2+
 1. Switch the circuit breaker to "OFF" position. The LED lamp de-energizes instantly.
 2. Stop the engine. Refer to section Stopping the engine.
1. Switch the circuit breaker to "OFF" position.
 2. Disconnect the light tower plug from the main power supply.

MAINTENANCE



Do all maintenance activities when the light tower is de-energized. Touching live electrical circuits can cause electric shock and can result in injury or death.

REGULAR INSPECTION

Do the following inspection regularly:

- Check for fuel leakage. Identify the source of leakage.
- Examine the exposed wires for wear, damage or cuts.
- Examine the winch cable for wear or damage.



Never use the light tower if components are damaged. It can cause an accident which can result in injury or death.

REPLACING THE LAMP

The LED lamp has an average life of 50,000 running hours. The LED should be replaced only if it does not get energized after service from a certified technician.



Lamps will last longer if used carefully.

1. Replacing the lamp for HiLight V3+

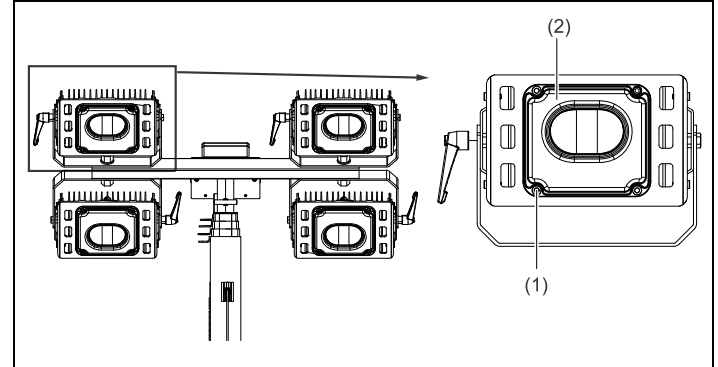

- Remove the 4 screws (1) using a pneumatic tool.
- Remove the LED protective cover (2).
- Disconnect the LED power lines.
- Replace the LED.
- Re-connect the power lines to the LED.
- Fit the LED protective cover (2) to the lamp using the 6 screws (1).

2. Replacing the lamp for HiLight V2+ and HiLight P2+

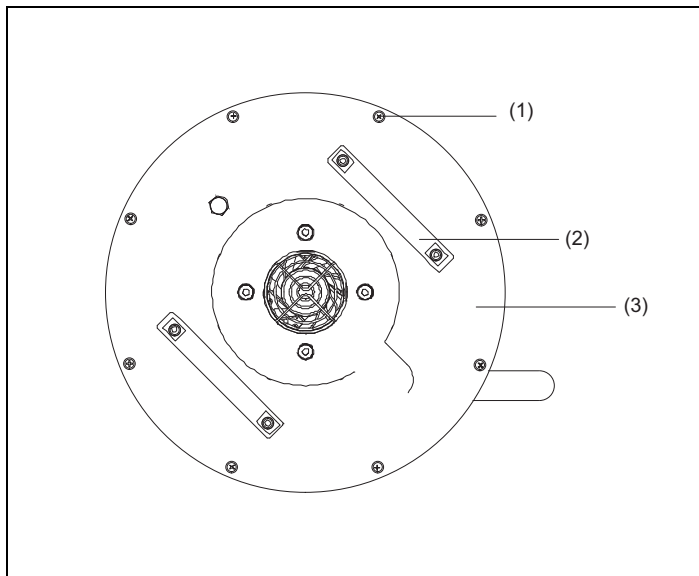

- a) Remove the 8 screws (1) using a pneumatic tool.
- b) Lift and remove the LED protective cover (3) by using the handles (2).
- c) Disconnect the LED power lines.
- d) Replace the LED.
- e) Re-connect the power lines to the LED.
- f) Fit the LED protective cover (3) using 8 screws (1).

ENGINE MAINTENANCE

Refer to the Engine Instruction Manual for precautions and maintenance of the engine.

Replacing parts

See the Parts Manual for more information.

MAINTENANCE SCHEDULE - P2000I

Maintenance Item Schedule (running hrs)	Routine	Pre-operation check (daily)	6 months or 100 hrs	12 months or 300 hrs
Spark plug	Check condition. Clean and replace if necessary.		X	
Fuel	Check fuel level and leakage.	X		
Fuel hose	Check fuel hose for cracks or damage, Replace if necessary	X		
Oil	Check oil level in engine.	X		
	Replace		X (1)	
Air filter	Check condition.		X (2)	
	Clean			
Muffler screen	Check condition. Clean and replace if necessary.		X	
Spark arrester	Check condition. Clean and replace if necessary.		X	
Fuel filter	Clean and replace if necessary.			X
Crankcase breather hose	Check hose weather for cracks or damage. Replace if necessary.			X
Cylinder head	Decarbonizes cylinder head More frequently if necessary			*
Valve clearance	Check and adjust when engine is cold.			*
Fittings / fasteners	Check all fittings and fasteners. Correct if necessary.			*
The point where abnormality was recognized by use.		X		

Note:

- (1) Initial replacement of the engine oil is after before one month or after 20 hours of operation.
- (2) The air filter needs to be cleaned more frequently when using in unusually wet or dusty areas.

* Since these items require tools, date and technical skills, you should find a local delaeer perform the service.

MAINTENANCE SCHEDULE - P3000 AND P6500

Schedule for regular maintenance		Per use		Every 50 hours or every 3 months (3)	Every 100 hours or every 6 months (3)	Every 300 hours or every year (3)
Engine oil	Inspect the oil level	X				
	Replace		X			
Air cleaner	Inspect	X				
	Clean			X (1)		
Fuel switch sediment cup	Clean				X	
Sprat plug	Clean				X	Replace
Valve clearance	Readjust					X
Cylinder head	Wash	Every 300 hours (2)				
Fuel tank and strainer	Wash	Every 2 years (2)				
Fuel tube	clean	Every 2 years (2)				

Note:

- (1) maintenance should be done frequently if the unit is use in dusty places.
- (2) maintenance should be done by the franchised dealer.
- (3) when the unit is used frequently, please do the maintenance according to the above mentioed intervals to ensure a long life span for the enerator.

TECHNICAL SPECIFICATIONS

Reference conditions

	Unit	HiLight V3+ with P2000I	HiLight V3+ with P3000	HiLight V3+ with P6500	HiLight V2+ with P2000I	HiLight V2+ with P3000	HiLight V2+ with P6500	HiLight P2+
Rated frequency	Hz	50 / 60	50 / 60	50 / 60	50 / 60	50 / 60	50 / 60	-
Rated speed	rpm	5000	3000	3000	5000	3000	3000	-
Generator service duty		PRP	PRP	PRP	PRP	PRP	PRP	-
Absolute inlet pressure	kPa	-	-	-	-	-	-	-
Relative air humidity	%	0	0	0	0	0	0	-
Air inlet temperature	°C	20	20	20	20	20	20	-

Limitations

	Unit	HiLight V3+ with P2000I	HiLight V3+ with P3000	HiLight V3+ with P6500	HiLight V2+ with P2000I	HiLight V2+ with P3000	HiLight V2+ with P6500	HiLight P2+
Maximum ambient temperature	°C	-	-	-	-	-	-	-
Altitude capability	m	3500	3500	3500	3500	3500	3500	-
Relative air humidity maximum	%	-	-	-	-	-	-	-
Minimum starting temperature unaided	°C	-10	-10	-10	-10	-10	-10	-
Minimum starting temperature aided	°C	-25	-25	-25	-25	-25	-25	-

Performance data

	Unit	HiLight V3+ with P2000I	HiLight V3+ with P3000	HiLight V3+ with P6500	HiLight V2+ with P2000I	HiLight V2+ with P3000	HiLight V2+ with P6500	HiLight P2+
1. Rated active power (PRP) 1ph	kW	1.6	2.3	5	1.6	2.3	5	-
2. Rated power factor (lagging) 1phase	cos f	1	1	1	1	1	1	-
3 Rated apparent power 1ph	kVA	1.6	2.3	5	1.6	2.3	5	-
4 Rated voltage 1ph line to line.	V	230 / 120	230 / 240/120	230 / 240/120	230 / 120	230 / 240/120	230 / 240/120	-
5 Rated current 1ph.	A	7 / 13.3	10/9.6/19.2	21.7/20.8/41.7	7 / 13.3	10/9.6/19.2	21.7/20.8/41.7	-
6 Fuel consumption at full load (0%)	g/h	313	420	1017	313	420	1017	-
7 Specific fuel consumption (at 4 lamps on)	g/kWh	997.93	1000	2091.25	997.93	1000	2091.25	-
8 Fuel autonomy at 4 lamps on with fuel tank	h	5	11	10	5	11	10	-
9 Maximum sound power level (LWA) measured according to 2000/14/EC OND	dB(A)	90	95	97	90	95	97	-
10 Capacity of fuel tank	l	4	15	25	4	15	25	-
11 LED lamp	W	4x120	4x120	4x120	320	320	320	320
12 Luminous Flux for luminaire	Lm	4X 12000 ~ 4 X12500	4X 12000 ~ 4 X12500	4X 12000 ~ 4 X12500	28000-31000	28000-31000	28000-31000	28000-31000
13 Light High	mm	2005~5100	2005~5100	2005~5100	2005~5100	2005~5100	2005~5100	2230~3460

DATA PLATE

The data plate is on the Base frame of the light tower.

