

Operator's manual

Drive motor M1500, M2500 for modular internal vibrator HMS



Model	M1500, M2500
Document	5100011253
Issue	06.2015
Version	03
Language	en



Manufacturer

Wacker Neuson Produktion GmbH & Co. KG

Preußenstraße 41

80809 München

www.wackerneuson.com

Tel.: +49-(0)89-354 02-0

Fax: +49-(0)89-354 02-390

Translation of the original operator's manual in German

1	Preface	5
2	Introduction	6
	2.1 Application of the manual	6
	2.2 Storage location of the manual	6
	2.3 Accident Prevention Regulations	6
	2.4 Additional information	6
	2.5 Target group	6
	2.6 Explanation of symbols	6
	2.7 Wacker Neuson Contact partner	7
	2.8 Limitation of liability	7
	2.9 Product identification of the machine	7
3	Security	8
	3.1 Policy	8
	3.2 Qualification of the operating personnel	10
	3.3 Protection equipment	10
	3.4 Transport	11
	3.5 Operating safety	11
	3.6 Safety when operating hand-held equipment	12
	3.7 Safety when operating electrical equipment	12
	3.8 Safety when operating modular internal vibrators	14
	3.9 Maintenance	14
4	General Power Tool Safety Warnings	15
5	Safety and information labels	18
6	Setup and function	19
	6.1 Standard package	19
	6.2 Application	19
	6.3 Application area	19
	6.4 Mode of operation	19
7	Components and operator's controls	20
	7.1 Components and operator's controls of the drive motor	20
	7.2 Components of the HMS	20
	7.3 Components of the flexible shaft (optional)	21
	7.4 Components of the vibrator head (optional)	21
8	Transport, entire system (HMS)	22
9	Assembly of the HMS	23
	9.1 Pre-assemble the vibrator head	23
10	Operation	25
	10.1 Before commissioning	25
	10.2 Commission	25
	10.3 Decommissioning	27
11	Maintenance	28
	11.1 Qualification of the maintenance personnel	28
	11.2 Maintenance schedule	28
	11.3 Maintenance work	29
12	Troubleshooting	34
13	Permissible combinations	35
	13.1 Drive motor – Flexible shaft – Vibrator head	35

14	Disposal	36
	14.1 Disposal of waste electrical and electronic equipment	36
15	Accessories	37
16	Technical data	38
	16.1 Drive motor	38
	16.2 Flexible shaft-E (optional)	38
	16.3 Flexible shaft-S (optional)	39
	16.4 Vibrator head standard (optional)	39
	16.5 Vibrator head HA (optional)	40
	16.6 Extension cable	40
17	Glossary	42

1 Preface

This operator's manual contains information and procedures for the safe operation and safe maintenance of your Wacker Neuson machine. For your own safety and to protect against injuries, you must thoroughly read the safety instructions, familiarize yourself with them and observe them at all times. This operator's manual is not a manual for extensive maintenance or repair work. Such work must be carried out by the Wacker Neuson service department or by certified technically trained personnel.

When building this machine, great value was placed on the safety of its operator. However, an improper operation or improper maintenance can pose hazards. Please operate and maintain your Wacker Neuson machine in accordance with the information in this operator's manual. It will reward your attention by providing you with a trouble-free operation and high availability.

Defective machine parts must be replaced immediately!

Please contact your Wacker Neuson contact partner for questions regarding operation or maintenance.

All rights are reserved, in particular the right of duplication and distribution.

Copyright 2015 Wacker Neuson Produktion GmbH & Co. KG

This operator's manual - even in part - may only be reproduced, used, processed, copied or distributed with the expressed, prior written consent from Wacker Neuson.

Any type of reproduction, distribution or storage on data carriers in any form or type that is not approved by Wacker Neuson represents a violation of the valid copyright and will be prosecuted.

We reserve the express right to technical changes that are used to improve our machines or raise the safety standard, even without special notice.

2 Introduction

2.1 Application of the manual

This manual is to be considered as part of the machine and must be securely stored for the entire service life. This manual is to be passed on to each subsequent owner or user of this machine.

2.2 Storage location of the manual

This manual is a component of the machine and must be stored in the immediate vicinity of the machine so as to be accessible to personnel at all times.

If the manual is lost or a second copy of this manual is needed, there are two options to obtain a replacement:

- Download from the Internet - www.wackerneuson.com
- Contact a Wacker Neuson contact partner.

2.3 Accident Prevention Regulations

In addition to the notes and safety instructions in this manual, the local accident prevention regulations and the national industrial safety regulations also apply.

2.4 Additional information

This manual applies to various machine types from one product series. For this reason, some illustrations may vary slightly in appearance from the acquired machine. In addition, version-specific components may be described that are not included in the standard package.

The information contained in this manual is based on machines that were manufactured at the time of printing. Wacker Neuson reserves the right to make unannounced modifications to this information.

It must be ensured that possible modifications or supplements on the part of the manufacturer are introduced in this manual immediately.

2.5 Target group

People who work with this machine must be trained regularly regarding the dangers of handling the machine.

This operator's manual is intended for the following people:

Operating personnel:

These people are instructed in the machine and are informed of possible dangers in the event of improper behavior.

Technically trained personnel:

These people have a professional training as well as additional knowledge and experience. They are able to evaluate the tasks assigned to them and recognize potential dangers.

2.6 Explanation of symbols

This manual contains particularly emphasized safety instructions in the categories: **DANGER**, **WARNING**, **CAUTION** and **NOTE**.

Before all work on and with this machine, the notes and safety instructions must have been read and understood. All notes and safety instructions in this manual must also be passed on to the maintenance, repair and transport personnel.



DANGER

This combination of the symbol and signal word indicates a hazardous situation that will result in death or serious injury if not avoided.



WARNING

This combination of the symbol and signal word indicates a hazardous situation that can result in death or serious injury if not avoided.

CAUTION

This combination of the symbol and signal word indicates a possible hazardous situation that can result in minor injury and damage to the machine if not avoided.

NOTE

Supplementary information.

2.7 Wacker Neuson Contact partner

Depending on your country, your Wacker Neuson contact partner is Wacker Neuson service, a Wacker Neuson affiliate or a Wacker Neuson dealer.

On the Internet under www.wackerneuson.com.

The manufacturer's address is found at the beginning of this manual.

2.8 Limitation of liability

For the following violations, Wacker Neuson dismisses any liability for personal injury or material damage:

- Failure to observe this manual.
- Application in accordance with the intended purpose.
- Application of untrained personnel.
- Use of spare parts and accessories that are not approved.
- Improper handling.
- Structural modifications of any kind.
- Failure to observe the "general terms and conditions" (GT&C).

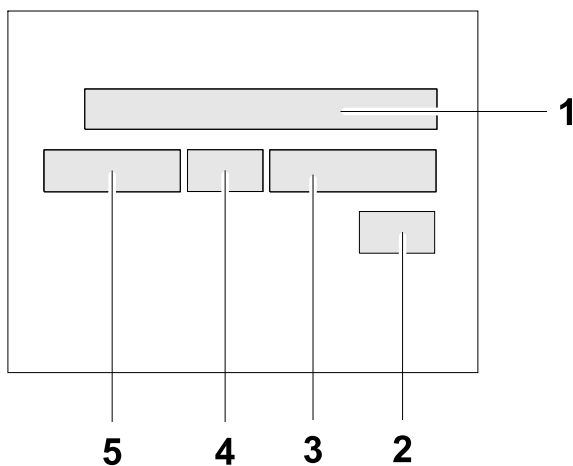
2.9 Product identification of the machine
Data of the nameplate

The nameplate contains information that uniquely identifies this machine. This information is required for ordering spare parts and when inquiring about technical issues.

- Enter the information about the machine in the following table:

Item	Designation	Your information
1	Group and model	
2	Year of manufacture	
3	Serial number	
4	Version number	
5	Item number	

3 Security

3.1 Policy

Prior Art

The equipment is built according to prior art and the recognized technical safety rules. Nevertheless, improper use can result in hazards to life and limb of the user or third parties or to damage to the equipment and other material assets.

Proper use

The equipment may only be used for the operation of flexible shafts and vibrator heads.

The equipment may only be combined with permissible components.

The equipment may only be operated with flexible shafts and vibrator heads permitted by Wacker Neuson.

The equipment may not be used for the following purposes:

- The connection of non-permissible components.
- Operation without a flexible shaft and vibrator head.

Other special applications must be tested and released by Wacker Neuson.

Use in accordance with the intended purpose also includes the observation of all notes in this operator's manual as well as complying with the prescribed care and maintenance instructions.

Any other or exceeding use is considered improper. The manufacturer's liability and warranty are canceled for any damage resulting from improper use. The risk lies entirely with the operator.

Structural changes

Do not carry out any structural changes without written approval from the manufacturer. You will thereby be endangering your safety and the safety of others! Additionally, the manufacturer's liability and warranty will be canceled.

In particular, the following cases are considered structural changes:

- Opening the device and permanent removal of components that originate from Wacker Neuson.
- Installing new components that do not originate from Wacker Neuson or are not comparable in the design system and quality of the original parts.
- Attaching accessories that do not originate from Wacker Neuson.

You can safely install spare parts that originate from Wacker Neuson.

You can safely attach accessories that are available for your equipment in the Wacker Neuson product range. To do so, please refer to the attachment regulation in this operator's manual.

For example, do not drill into the housing to attach signs. Water can enter into the housing and damage the equipment.

Prerequisite for operation

The flawless and safe operation of the equipment requires the following:

- Proper transport, storage and assembly.
- Careful operation.
- Careful care and maintenance.

Operation

Only operate the equipment in accordance with the intended purpose and in a technically flawless condition.

Only operate the equipment in a safety and hazard-conscious manner and with all protective devices. Do not change or bypass any protective devices.

Before beginning work, check the effectiveness of the operator's controls and protective devices.

Never operate the unit in explosive environments.

Supervision

Never leave equipment running without supervision!

**Maintenance**

Regular maintenance work is required for a flawless and permanent functioning of the equipment. Neglected maintenance reduces the equipment's safety.

- The prescribed maintenance intervals must be strictly observed.
- Do not use the equipment if maintenance or repairs are needed.

Faults

In the event of malfunctions, you must immediately switch the equipment off and secure it.

Immediately rectify faults that can impair safety!

Have damaged or defective components replaced immediately!

You can find more information in the chapter *Troubleshooting*.

Spare parts, accessories

Only use spare parts from Wacker Neuson or such spare parts that are comparable in the design system and quality of the original parts.

Only use accessories by Wacker Neuson.

Non-observance cancels out any liability.

Disclaimer

For the following violations, Wacker Neuson dismisses any liability for personal injury or material damage:

- Structural change.
- Improper use.
- Non-observance of this operator's manual.
- Improper handling.
- Using spare parts that do not originate from Wacker Neuson or are not comparable in the design system and quality of the original parts.
- Using accessories that do not originate from Wacker Neuson.

Operator's manual

Always keep the operator's manual readily available on the equipment or at the place of application of the equipment.

If you should lose the operator's manual or require another copy, please contact your Wacker Neuson contact partner or download the operator's manual from the Internet (www.wackerneuson.com).

Hand over this operator's manual to every other operator or subsequent owner of the equipment.

Country-specific regulations

Also observe country-specific regulations, standards and guidelines for accident prevention and environmental protection, such as dealing with hazardous substances and wearing personal protection equipment.

Supplement the operator's manual with additional instructions on taking operational, regulatory, national or generally applicable safety guidelines into consideration.

Operating elements

Always keep the equipment's operator's controls dry, clean and free from oil and grease.

Operator's controls, such as the ON/OFF switch, throttle control handles, etc. may not be locked, manipulated or changed without permission.

Check for damage

Check the shutdown equipment at least once per shift for externally visible damage and deficiencies.

Do not operate the equipment if damage or deficiencies are discernible.

Have damage and deficiencies rectified immediately.

3.2 Qualification of the operating personnel

Qualification of the operator

Only technically trained personnel may start and operate the equipment. In addition, the following conditions apply:

- They are physically and mentally suitable.
- They are trained in the independent operation of the equipment.
- They are trained how to use the equipment in accordance with the intended purpose.
- They are familiar with the necessary safety devices.
- They are authorized to operate equipment and systems independently according to the standards of safety engineering.
- They are appointed by the contractor or operator to independently work with the equipment.

Faulty operation

In the event of faulty operation, misuse or operation by untrained personnel, dangers threaten the health of the operator or third parties as well as the condition of the device or other material assets.

User responsibilities

The user must make the operator's manual available to the operator and ensure that the operator has read and understood them.

Recommendations for work

Please observe the following recommendations:

- Only work in a good physical condition.
- Work attentively, especially at the end of working hours.
- Do not work with the equipment when you are tired.
- Perform all work calmly, cautiously and carefully.
- Never work under the influence of alcohol, drugs or medication. Your vision, reactivity and judgment may be impaired.
- Work so that no third parties are harmed.
- Make sure that there are no people or animals in the danger area.

3.3 Protection equipment

Working clothes

The clothing should be appropriate, i.e. tight fitting, but not cumbersome.

Generally, do not have any long hanging hair, loose clothing or jewelry (including rings) during on construction sites. There is a risk of injury, for example from being snagged or pulled in on moving equipment parts.

Only wear flame-resistant working clothing.

Personal Protection Equipment

Use personal protection equipment in order to avoid injuries and health hazards:

- Safety shoes.
- Work gloves made from sturdy material.
- Overalls made from sturdy material.
- Protective helmet.
- Ear protection.
- Facial protection.
- Eye protection.

Ear protection

With this equipment, it is possible to exceed the permissible, country-specific noise limit (personal rating level). This is why you may have to wear ear protection under certain circumstances. You can find the exact value in the chapter *Technical data*.

Work particularly cautiously and pay attention when wearing ear protection, as your ability to hear noises, such as screams or signal tones, is restricted.

Wacker Neuson recommends always wearing ear protection.



3.4 Transport

Switch off the unit

Before transport, switch the equipment off and remove the plug from the plug receptacle. Allow the engine to cool down.

Transporting the equipment

Secure the equipment on the means of transport from tipping over, falling down or sliding.

Recommissioning

Before recommissioning, attach and fasten equipment, equipment parts, accessories or tools that were dismantled for transport purposes.

Proceed only according to the operator's manual.

3.5 Operating safety

Explosive area

Never operate the unit in explosive environments.

Work environment

Familiarize yourself with the work environment before beginning work. For example, this includes the following points:

- Obstacles in the work and traffic area.
- Load-bearing capacity of the soil.
- Necessary protection of the construction site, especially for the public transport area.
- Necessary protection of walls and ceilings.
- Options available in the event of accidents.

Safety in the working area

If you work with the equipment, pay particular attention to the following points:

- Pay maximum attention near drops or slopes. Risk of crashing.
- No people may be in the working area.

Checks before starting work with the HMS

Check the following points before starting work:

- Connection values of the drive motor.
- Condition of the individual components.
- Permissible combinations and connection links of the HMS.

Commissioning the HMS

Observe the safety instructions and warning notices on the drive motor as well as those in the operator's manual.

Never operate equipment that is in need of maintenance or repairs.

Operate the HMS according to the operator's manual from the drive motor.

Stability

Always ensure good footing when working with the HMS. This especially applies when working on scaffolding, ladders, uneven or slippery surfaces.

Beware of hot parts

Do not touch the hot vibrator head (component of HMS) during operation or shortly thereafter. The vibratory head can become very hot and cause burns.

Use caution with moving parts of the HMS

Keep hands, feet and loose clothing away from moving or rotating vibrator head (component of HMS).

Do not use components of the HMS as a climbing aid or securing means

Never use the protection hose, power cable or other components of the HMS as a climbing aid or securing means.

Protect the flexible shaft (component of the HMS)

Do not excessively bend or kink the flexible shaft.

Do not pull the flexible shaft over sharp edges.

If the flexible shaft has become jammed in the reinforcement, switch off the drive motor and disconnect the flexible shaft from the drive motor. Then release the clamped flexible shaft by carefully moving it back and forth.

Switch off the unit

Switch the equipment off and remove the plug from the plug receptacle in the following situations:

- Before breaks.
- When you are not using the equipment.

Before putting the equipment down, wait until it comes to a complete standstill.

Set the equipment down so that it cannot tip over, fall down or slip.

Storage

Set the equipment down so that it cannot tip over, fall down or slip.

Storage location

After operation, store the cooled equipment in a locked, clean, frost-protected and dry location that is inaccessible to children.

Vibration load of the HMS

Vibration-induced long-term damage cannot be ruled out entirely during intensive use of walk-behind drive motors.

Observe the respective statutory provisions and guidelines in order to keep the vibrations to a minimum.

You can find information about the vibration load of the HMS in the chapter *Technical Data*.

3.6 Safety when operating hand-held equipment

Working safely with hand-held equipment

While working, only hold the equipment by the handle intended solely for this purpose.

Always keep the power cable behind and away from the drive motor and keep the power cable away from the working area of the vibrator head.

Ensure that the air intakes and outlets are clear.

Setting down hand-held equipment properly

Carefully lay down the equipment. Do not throw the equipment on the floor or from great heights. When thrown down, the equipment can injure other people or even be damaged itself.

3.7 Safety when operating electrical equipment

Specific regulations for electrical equipment

Observe the safety instructions in the *General safety instructions* brochure from the equipment's standard package.

Also observe the country-specific regulations, standards and directives for accident prevention in conjunction with electrical systems and equipment.

 **WARNING** Read all safety instructions and information Failure to comply with the safety information and instructions can cause electric shock, fire and / or serious injuries.

Save all safety information and instructions for the future.

Electric power supply for electrical equipment of class rating II

NOTICE

The rated voltage can be found on the nameplate of your equipment.

You may only connect the equipment to electric power supplies if all device parts can be found in a technically perfect condition. In particular, pay attention to the following components:

- Plug.
- Power cable in its entire length.
- Switch membrane of the ON/OFF switch, if present.
- Plug receptacles.

Electrical equipment of class rating II has a reinforced or dual insulation (protective insulation) and does not have a connection to the grounded conductor.

With a mains connection, at least one of the following safety devices must be present at the point of connection:

- Protective ground fault interrupter (GFI or GFCI).
- Insulation monitor.
- IT net.
- Isolating transformer.

NOTICE

Observe the respective national safety directives!

Extension cable (accessories)

You may only operate the equipment with undamaged and tested extension cables!

You may only use extension cables with grounded conductors and a proper grounded conductor connection to the plug and coupling (only equipment of class rating I, see chapter *Technical data*).

You may only use tested extension cables that are suitable for construction site use: Wacker Neuson recommends H07RN-F, H07BQ-F, a SOOW-cable or a country-specific equivalent design.

You must immediately replace extension cables with damage (e.g. tears in the casing) or loose plugs and couplings.

Cable drums and multi-pole plug receptacles must meet the same requirements as extension cables. Protect extension cable, multi-pole plug receptacles, cable drums and connection couplings from rain, snow or other forms of moisture.

Completely unroll the cable drum (accessories)

Risk of fire if the cable drum is not completely unrolled.

Completely unroll the cable drum before operation.

Protect the power cable

Do not use the power cable to pull or lift the equipment.

Do not pull the plug of the power cable out of the plug receptacle by pulling the cable.

Protect the power cable from heat, oil and sharp edges.

Have your Wacker Neuson contact partner immediately replace damaged power cables or loose plugs.

Protect against moisture

Protect the equipment from rain, snow or other forms of moisture. Damage and other malfunctions are possible.

**Protect against excessively high or low temperatures**

Protect the equipment against excessively high or low temperatures. The insulation of live parts can otherwise be damaged.

You can find information about the permissible temperature range in the chapter *Technical data*.

3.8 Safety when operating modular internal vibrators**Shoulder strap**

Wacker Neuson recommends using a shoulder strap.

3.9 Maintenance**Maintenance work**

Care and maintenance work may only be carried out insofar as it is described in this operator's manual. All other work, such as the replacement of the power cable, must be performed by the Wacker Neuson contact partner in order to avoid safety hazards.

You can find more information in the chapter *Maintenance*.

Disconnect from the electric power supply

Before performing maintenance jobs, you must remove the plug from the plug receptacle in order to disconnect the equipment from the electric power supply.

Cleaning

Always keep the equipment clean and clean it after every use.

Do not use any fuels or solvents. Explosion hazard!

Do not use any high pressure washers. Ingressing water can damage the unit. With electrical equipment, there is a serious risk of injury from electric shock.

4 General Power Tool Safety Warnings



WARNING Read all safety warning, instructions, illustrations and specifications provided with this power tool. Failure to follow all instructions listed below may result in electric shock, fire and/or serious injury.

Save all warnings and instructions for future reference.

The term “power tool” in the warning refers to your mains-operated (corded) power tool or battery-operated (cordless) power tool.

1) Work area safety

- a) **Keep work area clean and well lit.** Cluttered or dark areas invite accidents.
- b) **Do not operate power tools in explosive atmospheres, such as in the presence of flammable liquids, gases or dust.**
- c) *Power tools create sparks which may ignite the dust or fumes.*
- d) **Keep children and bystanders away while operating a power tool.**
- e) *Distractions can cause you to lose control.*

2) Electrical safety

- a) **Power tool plugs must match the outlet. Never modify the plug in any way. Do not use any adapter plugs with earthed (grounded) power tools.** *Unmodified plugs and matching outlets will reduce risk of electric shock.*
- b) **Avoid body contact with earthed or grounded surfaces, such as pipes, radiators, ranges and refrigerators.** *There is an increased risk of electric shock if your body is earthed or grounded.*
- c) **Do not expose power tools to rain or wet conditions.** *Water entering a power tool will increase the risk of electric shock.*
- d) **Do not abuse the cord. Never use the cord for carrying, pulling or unplugging the power tool. Keep cord away from heat, oil, sharp edges or moving parts.** *Damaged or entangled cords increase the risk of electric shock.*
- e) **When operating a power tool outdoors, use an extension cord suitable for outdoor use.** *Use of a cord suitable for outdoor use reduces the risk of electric shock.*
- f) **When operating a power tool in a damp location is unavoidable, use a residual current device (RCD) protected supply.** *Use of an RCD reduces the risk of electric shock.*

3) Personal safety

- a) **Stay alert, watch what you are doing and use common sense when operating a power tool. Do not use a power tool while you are tired or under the influence of drugs, alcohol or medication.** *A moment of inattention while operating power tools may result in serious personal injury.*
- b) **Use personal protective equipment. Always wear eye protection.**



- c) *Protective equipment such as dust mask, non-skid safety shoes, hard hat or hearing protection used for appropriate conditions will reduce personal injuries.*
 - d) **Prevent unintentional starting. Ensure the switch is in the off-position before connecting to power source and/or battery pack, picking up or carrying the tool.**
 - e) *Carrying power tools with your finger on the switch or energizing power tools that have the switch on invites accidents.*
 - f) **Remove an adjusting key or wrench before turning the power tool on.**
 - g) *A wrench or a key left attached to a rotating part of the power tool may result in personal injury.*
 - h) **Do not overreach. Keep proper footing and balance at all times.**
 - i) *This enables better control of the power tool in unexpected situations.*
 - j) **Dress properly. Do not wear loose clothing or jewellery. Keep your hair and clothing away from moving parts.**
 - k) *Loose clothes, jewellery or long hair can be caught in moving parts.*
 - l) **If devices are provided for the connection of dust extraction and collection facilities, ensure these are connected and properly used.**
 - m) *Use of dust collection can reduce dust-related hazards.*
 - n) **Do not let familiarity gained from frequent use of tools allow you to become complacent and ignore, tool safety principles.**
 - o) *A careless action can cause severe injury within a fraction of a second.*
- 4) Power tool use and care**
- a) **Do not force the power tool. Use the correct power tool for your application. The correct power tool will do the job better and safer at the rate for which it was designed.**
 - b) **Do not use the power tool if the switch does not turn it on and off.**
 - c) *Any power tool that cannot be controlled with the switch is dangerous and must be repaired.*
 - d) **Disconnect the plug from the power source and/or the battery pack from the power tool before making any adjustments, changing accessories, or storing power tools.**
 - e) *Such preventive safety measures reduce the risk of starting the power tool accidentally.*
 - f) **Store idle power tools out of**
 - g) **the reach of children and do not allow persons unfamiliar with the power tool or these instructions to operate the power tool. Power tools are dangerous in the hands of untrained users.**
 - h) **Maintain power tools and accessories. Check for misalignment or binding of moving parts, breakage of parts and any other condition that may affect the power tool's operation. If damaged, have the power tool repaired before use.**
 - i) *Many accidents are caused by poorly maintained power tools.*
 - j) **Keep cutting tools sharp and clean.**

- k) *Properly maintained cutting tools with sharp cutting edges are less likely to bind and are easier to control.*
 - l) **Use the power tool, accessories and tool bits etc. in accordance with these instructions, taking into account the working conditions and the work to be performed.**
 - m) *Use of the power tool for operations different from those intended could result in a hazardous situation.*
 - n) **Keep handles dry, clean and free from oil and grease.**
 - o) *Slippery handles do not allow for safe handling and control of the tool in unexpected situations.*
- 5) Service**
- a) **Have your power tool serviced by a qualified repair person using only identical replacement parts. This will ensure that the safety of the power tool is maintained.**



5 Safety and information labels

There are labels on your unit that contain important instructions and safety information.

- Keep all labels legible.
- Replace missing or illegible labels.

The item numbers on the labels can be found in the parts book.



Item	Label	Description
1		Use personal protection equipment in order to avoid injuries and health hazards: <ul style="list-style-type: none"> ■ Ear protection. ■ Eye protection. Read the operator's manual before commissioning.
2		Observe the operative position.
3		Warning.

6 Setup and function

6.1 Standard package

The standard package includes:

- Drive motor.
- Shoulder strap.
- Operator's manual.

The HMS consists of several components, see chapter *Technical Data*:

- Drive motor.
- Flexible shaft (optional).
- Vibrator head (optional).

NOTICE

The components that are marked as "optional" must be ordered separately. You can find information about the assembly of an HMS in the chapter *Permissible combinations*.

6.2 Application

Only use the equipment in accordance with the intended purpose, see chapter *Safety, Use in accordance with the intended purpose*.

6.3 Application area

The drive motor may only be used for the operation of flexible shafts and vibrator heads.

You can use the combined HMS for the following activities:

- Compaction of freshly mixed (green) concrete.

6.4 Mode of operation

Principle

The drive motor drives the vibrator head via the flexible shaft, which generates high frequency vibrations. The vibrator head makes gyrations due to these vibrations.

The immersion of the vibrator head in the freshly mixed (green) concrete de-aerates and compacts the concrete in the operating area of the vibrator head.

At the same time, the freshly mixed (green) concrete cools the vibrator head.

NOTICE

The concrete is being compacted as long as air bubbles are rising.

7 Components and operator's controls

7.1 Components and operator's controls of the drive motor

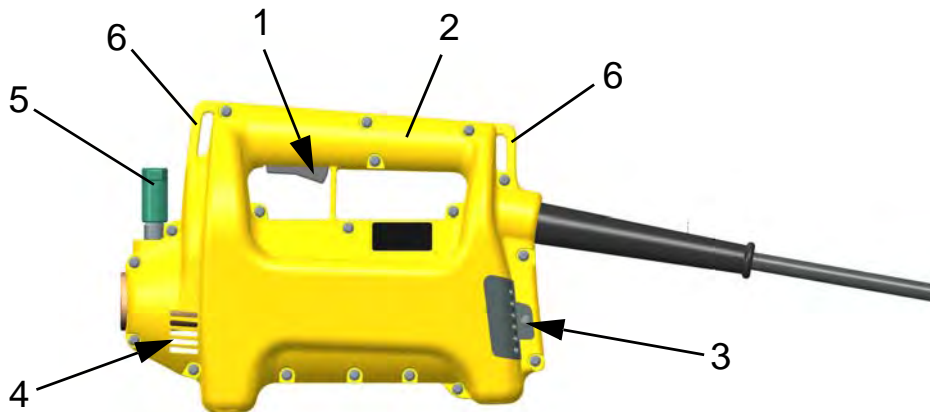

Item	Designation	Item	Designation
1	ON/OFF switch	4	Air outlet
2	Handle	5	T-Handle
3	Air inlet	6	Lugs for shoulder strap

T-Handle

The t-handle has different colors for the different versions, see chapter *Technical Data*.

With the t-handle, the quick disconnect coupling is opened so as to allow for a quick replacement and a secure connection link of the flexible shaft to the drive motor.

Air inlet and outlet

Airflow enters into the housing of the drive motor through the air cleaner element, cools the electric motor and exits through the ventilation slots. The airflow is represented by arrows in the drawing.

7.2 Components of the HMS

Depending on the application conditions, you can combine these components in different designs.

You can find information about the assembly of an HMS in the chapter *Permissible combinations*.

The HMS is composed of the following components:

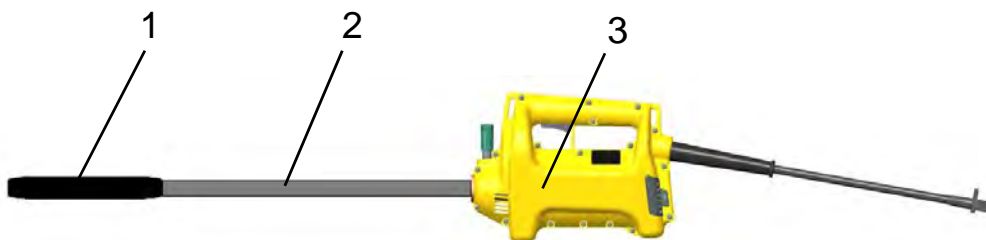

Item	Designation	Item	Designation
1	Vibrator head (optional)	3	Drive motor
2	Flexible shaft (optional)		

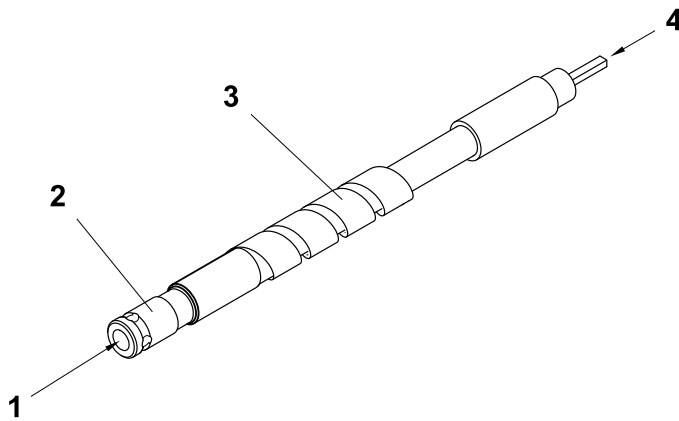
7.3 Components of the flexible shaft (optional)

Item	Designation	Item	Designation
1	Connection to the drive motor	3	Bend protection
2	Coupling piece	4	Connection to vibrator head

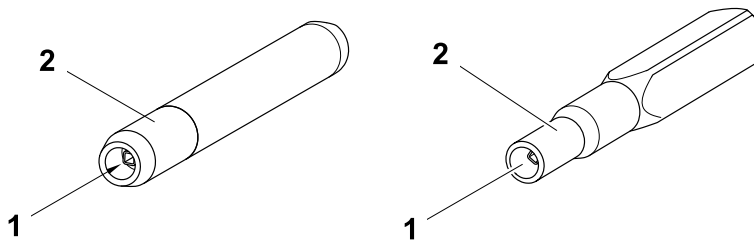
7.4 Components of the vibrator head (optional)

Item	Designation	Item	Designation
1	Fitting	2	Shaft core adapter

8 Transport, entire system (HMS)



WARNING

Improper handling can lead to injuries or serious damage to property.

- Read and observe all safety instructions in this operator's manual, see chapter *Safety*.
-



WARNING

Hot vibrator head.
Contact may cause burns.

- Only touch the vibrator head once the engine has cooled down.
 - Wear protective gloves.
-

Perform preparations

1. Switch the drive motor off with the ON/OFF switch.
2. Wait until the HMS come to a complete standstill.
3. Pull the plug out of the plug receptacle.
4. Disconnect the flexible shaft (including vibrator head) from the drive motor.
5. Allow the drive motor and vibrator head to cool down.

Transporting the equipment

1. Place the drive motor in or on a suitable transport means (operative position).
2. Wind up the power cable.

NOTICE

Do to kink the power cable!

3. Place the flexible shaft (including the vibrator head) in or on the suitable transport means as well.
4. Secure all components against falling down or sliding away.

Shoulder strap for drive motor

For longer flexible shafts, please use a shoulder strap to facilitate work.

You can carry the drive motor with the shoulder strap if you have to change your position frequently.

9 Assembly of the HMS

9.1 Pre-assemble the vibrator head

WARNING

Rotating parts.
Hand injuries are possible.

- Switch off the drive motor.
- Disconnect the flexible shaft from the drive motor.

Working in the workshop

Perform maintenance jobs in a workshop on a workbench. This has the following advantages:

- Protection of the equipment from dirt on the construction site.
- A level and clean working surface makes work easier.
- Small parts are easier to see and therefore are harder to lose.

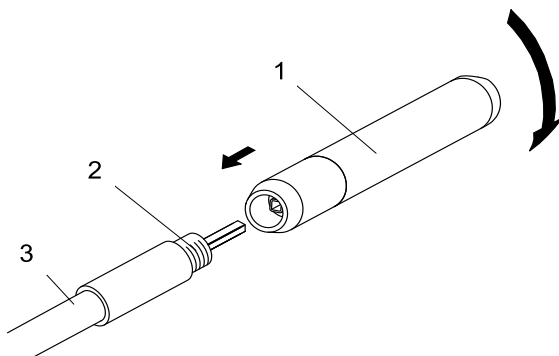
Screw the vibrator head onto the flexible shaft

Item	Designation	Item	Designation
1	Vibrator head	3	Flexible shaft
2	Thread		

1. Clamp the flexible shaft in a vise with prism jaws.
2. Apply pipe thread seal to the thread of the flexible shaft.
3. Place the vibrator head with the thread on the flexible shaft while inserting the shaft core into the shaft core adapter of the vibrator head.
4. Screw the vibrator head onto the flexible shaft (note the left hand thread!) and tighten with a pipe wrench.
5. Allow the pipe thread seal to cure for 24 hours.

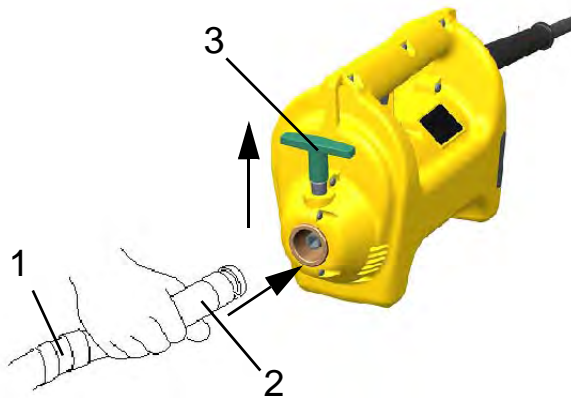
Connect the flexible shaft to the drive motor

Item	Designation	Item	Designation
1	Flexible shaft	3	T-Handle
2	Coupling piece		

1. Switch the drive motor off with the ON/OFF switch.
2. Pull the plug out of the plug receptacle.
3. Place the drive motor on the ground.
4. Pull the t-handle upwards.
5. Insert the coupling of the flexible shaft into the quick disconnect coupling of the drive motor and note the detent. In the process, the shaft core is received in the shaft core adapter of the drive motor.
6. Release the t-handle.
7. Rotate the flexible shaft until the quick disconnect coupling locks into place.
8. Pull on the flexible shaft to control whether the quick disconnect coupling is completely locked into place.

NOTICE

If the shaft core of the flexible shaft is new, you have to run in the drive motor for about 5 minutes with a connected flexible shaft (possibly also with the vibrator head).

10 Operation

**WARNING**

Improper handling can lead to injuries or serious damage to property.

- Read and observe all safety instructions in this operator's manual, see chapter *Safety*.

**WARNING**

Leak current due to moisture penetration.

Injury from electric shock.

- In a humid environment, hold or stop the equipment in the operative position.
- Use the extension cable in IPx4 design so that the connection link of the plug / coupling is splash-water protected.

10.1 Before commissioning

Previous conditions for operation

The HMS may only be operated under the following previous conditions:

- The HMS is pre-assembled according to this operator's manual:
 - The vibrator head is bolted onto the flexible shaft.
 - The flexible shaft (including vibrator head) is coupled with the drive motor.

NOTICE

For longer flexible shafts, Wacker Neuson recommends using a shoulder strap.

Check equipment

- Check the HMS and all components for damage.
- Check for a firm seat of the flexible shaft in the drive motor.
- Check the shoulder strap for damage.

Check the power supply system

- Check whether the power supply system or construction site electrical distributor has the correct operating voltage (see nameplate of the equipment or chapter *Technical Data*).
- Check whether the power supply system or construction site electrical distributor are verified according to the applicable national standards and guidelines.

10.2 Commission

Connect the HMS to the electric power supply**NOTICE**

Electrical voltage.

An incorrect voltage can damage the equipment.

- Check whether the voltage of the power source conforms to the specifications of the equipment, see chapter *Technical Data*.

**WARNING**

Electrical voltage.

Injury from electric shock.

- Check power cable and extension cable for damage.
- Only use extension cables whose grounded conductor is connected to the plug and coupling (only for equipment of class rating I, see chapter *Technical data*).

**WARNING**

Start-up of the equipment.
Risk of injury from uncontrolled start-up of the equipment.

- Switch the equipment off before connecting to the electric power supply.

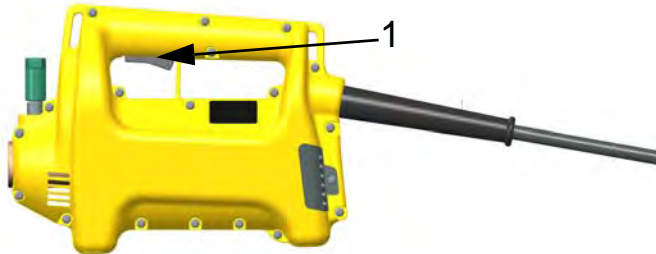
Switch on the equipment

Item	Designation
1	ON/OFF switch

1. Hold the equipment with one hand.
2. With the other hand, lift the protection hose so that the vibrator head does not beat around.
3. Switch the equipment on with the ON/OFF switch.

NOTICE

For flexible shafts longer than 2 meters, designate a helper to lift the vibrator head on the protection hose off the ground to avoid damage to the equipment or the subgrade.

Compacting freshly mixed (green) concrete

1. Quickly immerse, submerge the vibrator head into the freshly mixed (green) concrete, wait for a few seconds and slowly pull it out.
2. Immerse the vibrator head in all areas of the formwork and compact the freshly mixed (green) concrete.

NOTICE

- Compact particularly intensely within the range of formwork corners, because the spacing between the steel rods is the narrowest there.
- **Avoid the vibrator head coming into contact with the reinforcement. If the vibrator head comes into contact with the reinforcement, the following damage may occur:**

- The connection of the concrete to the reinforcement may be lost.
- The equipment may be damaged.

The result of the compaction depends on the following factors:

- The time the vibrator head is in the concrete.
- The diameter of the vibrator head.
- The consistency of the concrete.
- Narrow spacing between the steel rods.

If you, for example, use a vibrator head with a small diameter, you have to compact for longer to achieve the same effect as with a large diameter.

Features of when the concrete has been sufficiently compacted:

- The concrete is no longer settling.
- Little to no air bubbles are rising any longer.
- The sound of the vibrator head no longer changes.

10.3 Decommissioning

Switch off the unit



CAUTION

Proper motion of the running vibrator head outside of the freshly mixed (green) concrete. Risk of injury or danger of property damage due to beating around vibrator head.

- Switch the equipment off before setting it down.
-



CAUTION

Warming up the running vibrator head outside of the freshly mixed (green) concrete. Risk of burning from hot surface.

Damage to the equipment from increased wear.

- Do not run the equipment outside of the freshly mixed (green) concrete.
-

1. Slowly pull the vibrator head out of the freshly mixed (green) concrete and hold it in the air.
2. Switch the equipment off with the ON/OFF switch.
3. Wait until the equipment has come to a complete standstill.
4. Slowly stop the equipment (operative position) and set down the corresponding flexible shaft and vibrator head.

NOTICE

Do not bend the protection hose and power cable.

5. Pull the plug out of the plug receptacle.
6. Allow the equipment to cool down.

Disconnect the flexible shaft from the drive motor



CAUTION

Risk of burning from hot coupling of the flexible shaft.

- Only touch the coupling with protective gloves.
-

1. Pull the t-handle.
2. Pull the coupling of the flexible shaft out of the quick disconnect coupling of the drive system.
3. Release the t-handle.
4. Safely place the equipment down on level and stable surface so that the drive motor cannot tip over, fall over or slip away.

Clean equipment

Clean all components of the HMS after every application.

1. Clean the vibrator head and flexible shaft with water.

NOTICE

With the equipment running, you can remove the concrete residue from the vibrator head by immersing it in a gravel bed.

2. Wipe down the drive motor and flexible shaft with a damp clean cloth.
3. Clean the ventilation slots with an appropriate, non-metallic auxiliary tool.

11 Maintenance

WARNING

Improper handling can lead to injuries or serious damage to property.

- Read and observe all safety instructions in this operator's manual, see chapter *Safety*.

WARNING

Electrical voltage.
Injury from electric shock.

- Pull the plug out of the plug receptacle before all work on the equipment.

WARNING

Risk of death from electric shock in the event of improper work.

- According to the applicable guidelines, opening the equipment, repairing and a subsequent safety control may only be performed by a qualified electrician.

WARNING

Hot equipment
Contact may cause burns.

- Only touch the equipment once the engine has cooled down.

11.1 Qualification of the maintenance personnel

Qualification for maintenance work

The maintenance work described in this operator's manual may be performed by any responsible operator, unless indicated otherwise.

Some maintenance work may only be performed by special technically trained personnel or by the service department of your Wacker Neuson contact partner — these jobs are marked separately.

11.2 Maintenance schedule

NOTICE

The time intervals named here are standard values for normal operation. Halve the maintenance intervals for extreme operation, e.g. long-time application.

11.2.1 Drive motor

Activity	Daily before operation	Every 50 hours	Every 500 hours
Check the power cable to ensure a flawless condition. If defective, replace the power cable.*	■		
Visual inspection of all elements for damage.	■		
Clean equipment: <ul style="list-style-type: none"> ■ Air inlet: ■ Ventilation slots at the air outlet. 	■		
Clean the filter element.		■	
Check the carbon brushes and exchange if necessary.*			■
* Have this work performed by the service department of your Wacker Neuson contact partner.			

11.2.2 HMS

Activity	Daily before operation	Every 50 hours	Every 100 hours	Every 300 hours
Visual inspection of all elements for damage.	■			
Check to ensure the connection links are firmly seated: <ul style="list-style-type: none"> ■ Flexible shaft – vibrator head: tighten if necessary. ■ Flexible shaft – drive motor: securely lock the coupling into place if necessary. 	■			
Clean HMS.	■			
Check wear dimensions of the vibrator head.		■		
Lubricate the flexible shaft and exchange the plastic bushing.			■	
Replace the oil in the vibrator head.*				■
* Have this work performed by the service department of your Wacker Neuson contact partner.				

11.3 Maintenance work
Working in the workshop

Perform maintenance work in a workshop on a workbench. This has the following advantages:

- Protection of the equipment from dirt on the construction site.
- A level and clean working surface makes work easier.
- Small parts are easier to see and therefore are harder to lose.

Visual inspection for damage

WARNING

Damage to an equipment part or power cable can lead to physical injury from electric shock.

- Do not operate damaged equipment.
- Have damaged equipment repaired immediately.

- Check all components of the HMS for damage.
- Check the drive motor for damage or cracks.
- Check to ensure the ON/OFF switch of the drive motor is functioning.

11.3.1 Clean HMS

Clean the HMS after application.

NOTICE

Do not clean the equipment with high pressure or steam cleaners!

- Wipe down the drive motor and flexible shaft with a damp clean cloth.
- Clean the ventilation slots with an appropriate, non-metallic auxiliary tool.
- Clean the vibrator head and protection hose with water.

NOTICE

With the equipment running, you can remove the concrete residue from the vibrator head by immersing it in a gravel bed.

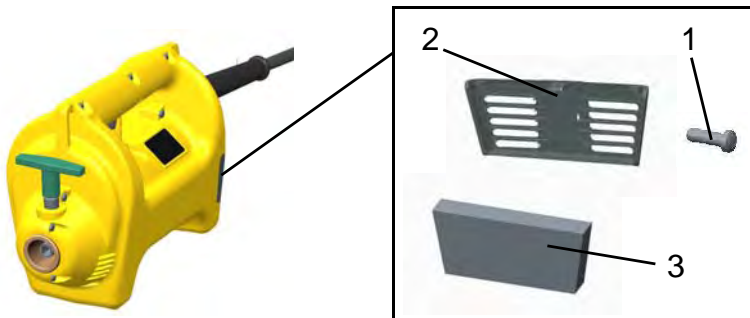
11.3.2 Drive motor
Clean the filter element

Item	Designation	Item	Designation
1	Screw	3	Filter element
2	Cover		

1. Switch the ON/OFF switch off.
2. Wait until the equipment has come to a complete standstill.
3. Pull the plug out of the plug receptacle.
4. Loosen the screw and pull out the cover.
5. Remove the filter element and wash out with clean water.

NOTICE

Exchange the filter element if it is very dirty.

6. Use a dry filter element and ensure the correct fitting position.
7. Insert the cover.
8. Hand-tighten the screw.

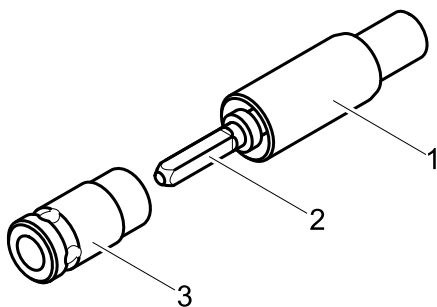
11.3.3 Flexible shaft
Remove the shaft core

Item	Designation	Item	Designation
1	Flexible shaft	3	Coupling piece
2	Shaft core		

1. Remove dirt accumulation within the range of the coupling.
2. Clamp the flexible shaft in a vise with prism jaws.
3. Unscrew the coupling with a large pipe wrench or special wrench (accessory).

4. Remove the shaft core entirely from the protection hose.
5. Wipe down the shaft core with a clean, lint-free cloth.

NOTICE

Do not clean the shaft core or the protection hose with a solvent!

6. Clean the thread of the coupling and the flexible shaft with a wire brush and cleaning agent.

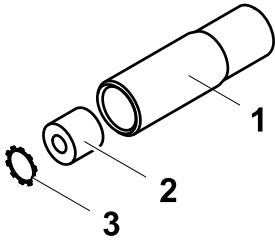
Exchange the plastic bushing

Item	Designation	Item	Designation
1	Flexible shaft	3	Retaining clip
2	Plastic bushing		

1. Remove the retaining clip with a screwdriver.
2. Pull out the plastic bushing, if necessary with a removal tool.
3. Wipe down the bearing point with a clean, lint-free cloth.
4. Insert new plastic bushing.
5. Insert the retaining clip with a curvature inwards until all teeth lock into place in the groove.

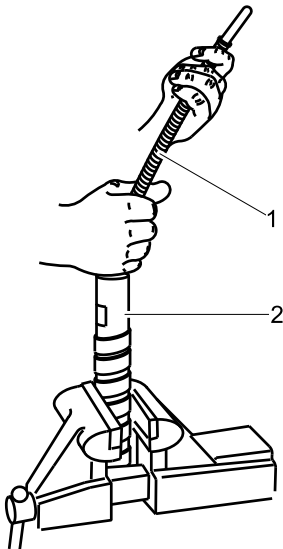
Lubricate the shaft core

Item	Designation	Item	Designation
1	Shaft core	2	Protection hose

NOTICE

You have to exchange the flexible shaft if it displays damage or wear tracks.

- Lightly grease the shaft core with your hands with an even thin layer of special lubricant (accessory).

Assemble the flexible shaft

1. Insert the shaft core completely to the protection hose and rotate in the process.
Rotating the shaft core spreads the special lubricant.
2. Insert the shaft core into the shaft core adapter of the vibrator head.
3. Apply pipe thread seal (accessory) to the thread of the coupling.
4. Screw the coupling onto the flexible shaft and tighten with a large pipe wrench or special wrench (accessory).
5. Check the shaft core for smooth and effortless movement while rotating with a special wrench (accessory).

NOTICE

If the shaft core is new, you have to run in the drive motor for about 5 minutes with a connected flexible shaft (possibly also with the vibrator head).

11.3.4 Vibrator head
Check wear dimensions of the vibrator head
The wear dimensions are:

- Minimum diameter of vibrator head (H-vibrator head).
- Minimum wrench size of the square (HA-vibrator head).

The wear is highest at the end of the vibrator head.

If a wear dimension is reached at one point, have the tube bottom exchanged by your Wacker Neuson contact partner.

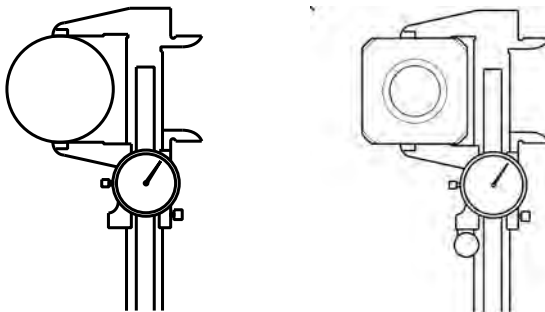

Vibrator head	Wear dimensions [mm]	Original dimensions [mm]
H 25, H 25S	24.0	25.0
H 35, H 35S	32.0	35.0
H 45, H 45S	41.0	45.0
H 55	52.0	57.0
H 65	58.0	65.0
H 25HA	25.0	26.2
H 35HA	32.0	36.0
H 45HA	39.0	45.0
H 50HA	46.0	50.0

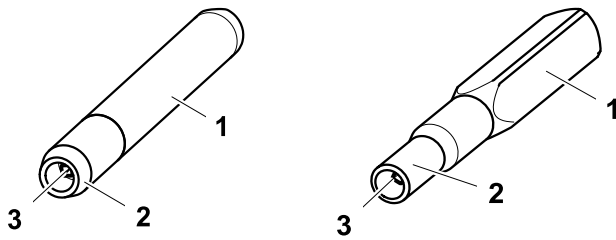
Replace the oil in the vibrator head

Item	Designation	Item	Designation
1	Housing	3	Shaft core adapter
2	Fitting		

Open the vibrator head

1. Remove dirt accumulation within the range of the fitting.
2. Clamp the flexible shaft in a vise with prism jaws.
3. Unscrew the vibrator head from the flexible shaft with a large pipe wrench (note the left hand thread!).
4. Clean the thread of the vibrator head and the flexible shaft with a wire brush and cleaning agent.
5. Clamp the vibrator head within the range of the fitting.
6. Unscrew the housing from the fitting with a large pipe wrench.

Replace oil

1. Pour out the oil and dispose of it in an environmentally friendly manner.
2. Clean the thread of the fitting and the vibrator head with a wire brush and cleaning agent.
3. Fill the oil in the housing to the suitable quantity according to the specifications, see chapter *Technical Data*.

Assemble the vibrator head

1. Apply pipe thread seal to the thread of the housing.
2. Screw the housing onto the fitting and tighten with a large pipe wrench.
3. Apply pipe thread seal to the thread of the flexible shaft.
4. Place the vibrator head with the thread on the flexible shaft while inserting the shaft core into the shaft core adapter of the vibrator head.
5. Screw the vibrator head onto the flexible shaft (note the left hand thread!) and tighten with a large pipe wrench.
6. Allow the pipe thread seal to cure for 24 hours.

12 Troubleshooting

You can find possible faults, their causes and solutions in the following table.

Fault	Cause	Remedial measure
HMS does not work.	The power supply is interrupted.	Check the power cable. If defective, have it exchanged.*
	Worn carbon brushes.	Exchange the carbon brushes.*
	Defective ON/OFF switch.	Have the ON/OFF switch exchanged.*
	Electric power supply safeguard triggered.	Activate safeguard.
	Burned out drive motor.	Exchange drive motor.*
HMS skips.	Worn carbon brushes.	Exchange the carbon brushes.*
Drive motor is running very loudly.	Broken carbon brushes.	Exchange the carbon brushes.*
	Worn bearing of the drive motor.	Have the equipment parts exchanged.*
	Rotor grinding on the stator.	
Drive motor is running normally, but is overheating.	The filter element or air inlet is obstructed.	Remove the dirt; exchange the filter element if necessary.
	Too much special lubricant in the connected flexible shaft.	Remove excess special lubricant with a cloth or exchange the flexible shaft.
	Too much oil in the vibrator head.	Remove excessive oil.*
Drive motor is running slowly and is overheating.	Input voltage too low.	Establish the correct supply voltage.
	The cross-section of the extension cable is too small.	Use an extension cable with a sufficient cross-section.
	Incorrect combination of vibrator head and flexible shaft.	Use a combination according to the table, see chapter <i>Technical Data</i> .
	Shaft core of the flexible shaft insufficiently lubricated.	Lubricate the shaft core.
	Bearing of the vibrator head or the drive system worn.	Have the equipment parts exchanged.*
	Rotor grinding on the stator.	
* Have this work performed by the service department of your Wacker Neuson contact partner.		

13 Permissible combinations

You can combine these components in different designs, depending on the application conditions.

13.1 Drive motor – Flexible shaft – Vibrator head

NOTICE

Excessively large vibrator heads or excessively long flexible shafts overload the drive motor.

Excess wear and damage to the components is possible.

- Only use permissible combinations of components.

Vibrator head	Flexible shafts		
	SM1-E	SM2-E	SM4-E
H25	M1500 or M2500		
H25 S			
H25 HA			

Vibrator head	Flexible shafts							
	SM0-S	SM1-S	SM2-S	SM3-S	SM4-S	SM5-S	SM7-S	SM9-S
H35	M1500 or M2500							
H35 S								
H35 HA								
H45								
H45 S								
H45 HA								
H50 HA	M2500							
H55								
H65								
HR48*								
HR65*								
HR70*								
HR70 S*								

* Not available in every region.

14 Disposal

14.1 Disposal of waste electrical and electronic equipment

For customers in EU countries

This device is subject to the European Directive on waste electrical and electronic equipment (WEEE) and the corresponding national legislation. The WEEE directive outlines the procedure for handling electrical waste equipment across the EU.



The device is labelled with the symbol of a crossed out dustbin shown here. This means you may not dispose of it with normal household waste but in a separate environmentally-friendly waste collection.

This device is a professional electrical tool designed for commercial applications only (B2B device according to WEEE directive). Contrary to equipment used in most private households (B2C devices), in some EU countries such as Germany, this device may not be disposed of at a collection point in a public disposal facility (for example at public waste depots). In case of doubt, ask the sales outlet about the proper disposal procedure for B2B electrical equipment in your country and ensure you dispose of the device in accordance with the valid legal guidelines. Please also note any information in the sales contract and the general terms and conditions from the point of sales.

The proper disposal of this device prevents the occurrence of any negative effects on people or the environment, follows the specific procedures for handling harmful substances and enables valuable raw materials to be recycled.

For customers in non-EU countries

The proper disposal of this device prevents the occurrence of any negative effects on people or the environment, follows the specific procedures for handling harmful substances and enables valuable raw materials to be recycled. Therefore, we recommend that this device is disposed of in a separate, environmentally-friendly waste collection and not with normal household waste. In some cases, national legislation also stipulates the separate disposal of electric and electronic products. Please ensure you dispose of this device in accordance with the valid regulations in your country.

15 Accessories

A wide range of accessories is offered for the equipment.

You can find information about the individual accessories on the Internet at www.wackerneuson.com.

Special wrench for the flexible shaft

With the special wrench, you can disassemble the coupling of the flexible shaft more easily.

Pipe thread seal

You need the pipe thread seal to seal the threaded connections between the vibrator head and flexible shaft as well as between the coupling and the flexible shaft.

Special lubricant for the flexible shaft

You need the Wacker Neuson special lubricant to lubricate flexible shaft cores in flexible shafts.

16 Technical data

16.1 Drive motor

Designation	Unit	M1500/120 US	M2500/120 US
Item no.		5100004500	5100006000
T-handle (color)		green	red
Rated current	A	12.5	15.0
Rated voltage	V	120	120
Rated frequency	Hz	50 – 60	50 – 60
Phases	~	1	1
Length	mm (in)	312 (12.3)	312 (12.3)
Width	mm (in)	154 (6.1)	154 (6.1)
Height	mm (in)	230 (9.1)	230 (9.1)
Length of power cable	m (ft)	0,5 (1.6)	0,5 (1.6)
Weight	kg (lb)	4,9 (10.8)	5,4 (11.9)
Plug		NEMA 1-15P (Typ A)	NEMA 1-15P (Typ A)
Type of engine		Universal motor	Universal motor
Rated performance	kW	1,50	1,80
Nominal speed	min ⁻¹ (rpm)	11.500 (11,500)	12.000 (12,000)
Idle speed	min ⁻¹ (rpm)	14.000 (14,000)	16.000 (16,000)
Protection class		II	II
Protection		IP 24	IP 24
Sound pressure level L _{pA} *	dB(A)	85.0	85.0
Standards		DIN EN ISO 11201	
Vibration total value a _{hv}	m/s ² ft/s ²	5,0 (16.4)	5,0 (16.4)
Standards		DIN EN ISO 20643	
Uncertainty of measurement of the vibration total value a _{hv}	m/s ² ft/s ²	1,0 (3.3)	1,0 (3.3)
* Sound pressure level when operating the equipment at nominal speed and freely suspended play at 1 meter of distance			

16.2 Flexible shaft-E (optional)

Designation	Unit	SM1-E	SM2-E	SM4-E
Length	m (ft)	1,0 (3.3)	2,0 (6.6)	4,0 (13.1)
Weight	kg (lb)	1,5 (3.2)	2,5 (5.5)	4,3 (9.4)

**16.3 Flexible shaft-S (optional)**

Designation	Unit	SM0-S	SM1-S	SM2-S	SM3-S
Length	m (ft)	0,5 (1.6)	1,0 (3.3)	2,0 (6.6)	3,0 (9.8)
Weight	kg (lb)	1,3 (2.9)	2,7 (6.0)	4,3 (9.5)	5,9 (13.0)

Designation	Unit	SM4-S	SM5-S	SM7-S	SM9-S
Length	m (ft)	4,0 (13.1)	5,0 (16.4)	7,0 (23.0)	9,0 (29.5)
Weight	kg (lb)	7,1 (15.7)	9,3 (20.5)	12,9 (28.4)	15,1 (33.3)

16.4 Vibrator head standard (optional)

Designation	Unit	H25	H25 S	H35	H35 S
Swing play	mm (in)	1,1 (0.043)	0,8 (0.031)	2,2 (0.1)	1,7 (0.1)
Vibrations	1/min	12,000	12,000	12,000	12,000
Vibrations	Hz	200	200	200	200
Vibrator head shape		Round	Round	Round	Round
Vibrator head diameter / diagonal	mm (in)	25 (1.0)	25 (1.0)	35 (1.4)	35 (1.4)
Length of vibrator head	mm (in)	440 (17.3)	295 (11.6)	410 (16.1)	310 (12.2)
Weight	kg (lb)	1,3 (2.9)	0,8 (1.8)	2,1 (4.7)	1,7 (3.6)
Oil specification		Synthetic oil	Synthetic oil	Synthetic oil	Synthetic oil
Oil quantity	l	0.010	0.010	0.015	0.015

Designation	Unit	H45	H45 S	H55	H65
Swing play	mm (in)	2,7 (0.1)	1,8 (0.1)	3,1 (0.1)	3,2 (0.1)
Vibrations	1/min	12,000	12,000	12,000	12,000
Vibrations	Hz	200	200	200	200
Vibrator head shape		Round	Round	Round	Round
Vibrator head diameter / diagonal	mm (in)	45 (1.8)	45 (1.8)	57 (2.2)	65 (2.6)
Length of vibrator head	mm (in)	385 (15.2)	305 (12.0)	410 (16.1)	385 (15.2)
Weight	kg (lb)	3,4 (7.5)	2,8 (6.2)	5,3 (11.7)	6,2 (13.7)
Oil specification		Synthetic oil	Synthetic oil	Synthetic oil	Synthetic oil
Oil quantity	l	0.022	0.019	0.033	0.044

16.5 Vibrator head HA (optional)

Designation	Unit	H25HA	H35HA	H45HA	H50HA
Swing play	mm (in)	2,1 (0.1)	2,1 (0.1)	3,0 (0.1)	3,5 (0.1)
Vibrations	1/min	12,000	12,000	12,000	12,000
Vibrations	Hz	200	200	200	200
Vibrator head shape		Square	Square	Square	Square
Vibrator head diameter / diagonal	mm (in)	26 (1.0)	36 (1.4)	45 (1.8)	50 (2.0)
Length of vibrator head	mm (in)	380 (15.0)	405 (15.9)	390 (15.4)	395 (15.6)
Weight	kg (lb)	1,3 (2.8)	2,3 (5.1)	3,3 (7.3)	3,9 (8.6)
Oil specification		Synthetic oil	Synthetic oil	Synthetic oil	Synthetic oil
Oil quantity	l	0.010	0.020	0.030	0.050

16.6 Extension cable

WARNING

Electrical voltage.
Injury from electric shock.

- Check power cable and extension cable for damage.
 - Only use extension cables whose grounded conductor is connected to the plug and coupling (only for equipment of class rating I, see chapter *Technical data*).
-
- Only use permitted extension cables, see chapter *Safety*.
 - Find the necessary stranded conductor cross-section of the extension cable in the following table:

NOTICE

You can find the model designation and voltage of your equipment on the nameplate or using the item number from the chapter *Technical data*.

Machine	Voltage [V]	Extension [m]	Cross-section area of cable [mm ²]
M1500 US	120 1~	≤ 25	1,5
		≤ 42	2,5
		≤ 66	4,0
		≤ 98	6,0
		≤ 160	10,0
M2500 US	120 1~	≤ 21	1,5
		≤ 35	2,5
		≤ 55	4,0
		≤ 82	6,0
		≤ 133	10,0



Example: You have a M1500/120 and would like to use a 40-meter long extension cable.
The equipment has 120 V input voltage.
According to the table, your extension cable must have a stranded conductor cross-section of 2.5 mm².

US Machine

Machine	Voltage [V]	Extension ft	Cross-section area of cable AWG
M1500 US	120 1~	≤ 113	14
		≤ 179	12
		≤ 383	10
		≤ 442	8
M2500 US	120 1~	≤ 95	14
		≤ 149	12
		≤ 235	10
		≤ 368	8

17 Glossary

Class rating

The class rating according to DIN EN 61140 specifies the safety measures for electrical equipment to avoid electrocution. There are four class ratings:

Class rating	Meaning
0	No special protection apart from the basic insulation. No grounded conductor. Plug connection without grounded conductor contact.
I	Connection of all conductive housing components to the grounded conductor. Plug connection with grounded conductor contact.
II	Reinforced or double insulation (protective insulation). No connection to the grounded conductor. Plug connection without grounded conductor contact.
III	Machines are operated on protective low voltage (< 50 V). Connection to the grounded conductor is not necessary. Plug connection without grounded conductor contact.

Protection class IP

The protection class according to DIN EN 60529 indicates the suitability of electrical equipment for use in certain ambient conditions as well as the protection against risks.

The protection class is specified by an IP code according to DIN EN 60529.

Code	Meaning 1st number: Protection against touching hazardous parts. Protection against permeating foreign objects.
0	Not protected against contact. Not protected against foreign bodies.
1	Protected against contact with the back of the hand. Protected against large foreign objects with diameter > 50 mm (1.9 in).
2	Protected against contact with one finger. Protected against medium-sized foreign objects (diameter > 12.5 mm (0.5 in)).
3	Protected against touch with a tool (diameter > 2.5 mm (0.01 in)). Protected against small foreign objects with (diameter > 2.5 mm (0.01 in)).
4	Protected against touch with a wire (diameter > 1 mm (0.03 in)). Protected against granular foreign objects (diameter > 1 mm (0.03 in)).
5	Protected against contact. Protected against dust depositing inside.
6	Completely protected against any contact. Protected from dust.

Code	Meaning 2nd number: Protection against permeating water
0	Not protected against permeating water.
1	Protected against water dropping vertically.
2	Protected against diagonally falling water (15° angle).
3	Protected against spray (60° angle).
4	Protected against spraying water from all directions.
5	Protected against water jets (nozzle) from any angle.
6	Protected against strong water jets (overflow).
7	Protected from temporary immersion in water.
8	Protected from ongoing immersion in water.

